

Conclusion

Thus, the premises of this Leibnizian argument all seem to me to be more plausible than their negations. It therefore follows logically that the explanation for why the universe exists is to be found in God. It seems to me, therefore, that this is a good argument for God's existence.

Moreover, the Leibnizian argument is reinforced by the support which the *kalām* cosmological argument adds to premises (1) and (2). An essential property of a being that exists by a necessity of its own nature is that it be eternal, that is to say, without beginning or end. If the universe is not eternal, then it could fail to exist and so does not exist by a necessity of its own nature. But it is precisely the aim of the *kalām* cosmological argument to show that the universe is not eternal but had a beginning. It would follow that the universe must therefore be contingent in its existence. Not only so; the *kalām* argument shows the universe to be contingent in a very special way: it came into existence out of nothing. The atheist who would answer Leibniz by holding that the existence of the universe is a brute fact, an exception to the Principle of Sufficient Reason, is thus thrust into the very awkward position of maintaining, not merely that the universe exists eternally without explanation, but rather that for no reason at all it magically popped into being out of nothing, a position which might make theism look like a welcome alternative. Thus, the *kalām* argument not only constitutes an independent argument for a transcendent Creator but also serves as a valuable supplement to the Leibnizian argument.

Kalām Cosmological Argument

The *kalām* cosmological argument may be formulated as follows:

- 1) Whatever begins to exist has a cause.
- 2) The universe began to exist.
- 3) Therefore, the universe has a cause.

Conceptual analysis of what it means to be a cause of the universe then aims to establish some of the theologically significant properties of this being.

Whatever Begins to Exist Has a Cause

Premise (1) seems obviously true—at the least, more so than its negation. First and foremost, it's rooted in the metaphysical intuition that something cannot come into being from nothing. To suggest that things could just pop into being uncaused out of nothing is to quit doing serious metaphysics and to resort to magic. Second, if things really could come into being uncaused out of nothing, then it becomes inexplicable why just anything and everything do not come into existence uncaused from nothing. Finally, the first premise is constantly confirmed

in our experience. Atheists who are scientific naturalists thus have the strongest of motivations to accept it.

When I first wrote *The Kalām Cosmological Argument*, I figured that few atheists would deny the first premise and assert that the universe sprang into existence uncaused out of nothing, since I believed they would thereby expose themselves as persons interested only in an academic refutation of the argument and not in really discovering the truth about the universe. To my surprise, however, many atheists have taken this route. For example, Quentin Smith, commenting that philosophers are too often adversely affected by Heidegger's dread of "the nothing," concludes that "the most reasonable belief is that we came from nothing, by nothing, and for nothing"²⁷—a nice ending to a sort of Gettysburg address of atheism, perhaps.

Similarly, the late J. L. Mackie, in refuting the *kalām* cosmological argument, turns his main guns on this first step: "There is *a priori* no good reason why a sheer origination of things, not determined by anything, should be unacceptable, whereas the existence of a god [*sic*] with the power to create something out of nothing is acceptable."²⁸ Indeed, he believes *creatio ex nihilo* raises problems: (i) If God began to exist at a point in time, then this is as great a puzzle as the beginning of the universe. (ii) Or if God existed for infinite time, then the same arguments would apply to his existence as would apply to the infinite duration of the universe. (iii) If it be said that God is timeless, then this, says Mackie, is a complete mystery.

Now notice that Mackie never *refutes* the principle that whatever begins to exist has a cause. Rather, he simply demands what good reason there is *a priori* to accept it. He writes, "As Hume pointed out, we can certainly conceive an uncaused beginning-to-be of an object; if what we can thus conceive is nevertheless in some way impossible, this still requires to be shown."²⁹ But, as many philosophers have pointed out, Hume's argument in no way makes it plausible to think that something could really come into being without a cause. Just because I can imagine an object, say a horse, coming into existence from nothing, that in no way proves that a horse really could come into existence that way. The defender of the *kalām* argument is claiming that it is *really* impossible for something to come uncaused

27. *Theism, Atheism, and Big Bang Cosmology* (Oxford: Clarendon, 1993), 135. Smith's most recent criticism of the *kalām* cosmological argument is also a denial of the first premise, despite Smith's avowal that he now accepts the conclusion that the universe has a cause for its existence. Quentin Smith, "Kalām Cosmological Arguments for Atheism," in *The Cambridge Companion to Atheism*, ed. Michael Martin, Cambridge Companions to Philosophy (Cambridge: Cambridge University Press, 2007), 182–98. Smith's current position is that the initial singular point of the universe is not real and that therefore the sequence of instantaneous states of the universe is a beginningless series converging toward zero as a limit. Each state is caused by its predecessor and there is no first state. Any non-zero interval or state, such as the first second of the universe's existence, "is not caused by any or all of its instantaneous states and is not caused by any external cause" (ibid., 189). Smith takes "the beginning of the universe" to refer to the Planck era, that state which lasts until 10^{-43} second after the singularity. As a state of non-zero duration, the beginning of the universe therefore has no cause of any sort. The universe therefore comes into being uncaused out of nothing.

28. J. L. Mackie, *The Miracle of Theism* (Oxford: Clarendon, 1982), 94.

29. Ibid., 89.

from nothing. Does Mackie sincerely believe that things can pop into existence uncaused, out of nothing? Does anyone in his right mind really believe that, say, a raging tiger could suddenly come into existence uncaused, out of nothing, in this room right now? The same applies to the universe: if prior to the existence of the universe, there was absolutely nothing—no God, no space, no time—how could the universe possibly have come to exist?³⁰

In fact, Mackie's appeal to Hume at this point is counterproductive. For Hume himself clearly believed in the causal principle. In 1754 he wrote to John Stewart, "But allow me to tell you that I never asserted so absurd a Proposition as *that anything might arise without a cause*: I only maintain'd, that our Certainty of the Falseness of that Proposition proceeded neither from Intuition nor Demonstration, but from another source."³¹ Even Mackie confesses, "Still this [causal] principle has some plausibility, in that it is constantly confirmed in our experience (and also used, reasonably, in interpreting our experience)."³² So why not accept the truth of the causal principle as plausible and reasonable—at the very least more so than its denial?

Because, Mackie thinks, in this particular case the theism implied by affirming the principle is even more unintelligible than the denial of the principle. It makes more sense to believe that the universe came into being uncaused out of nothing than to believe that God created the universe out of nothing.

But is this really the case? Consider the three problems Mackie raises with *creatio ex nihilo*. Certainly, the proponent of the *kalām* argument would not hold (i) that God began to exist or (ii) that God has existed for an infinite number of, say, hours, or any other unit of time. But what is wrong with (iii), that God is, without creation, timeless? I would argue that God exists timelessly without creation and in time subsequent to creation.³³ This may be "mysterious" in the sense of "wonderful" or "awe-inspiring," but it is not, so far as I can see, unintelligible; and Mackie gives us no reason to think that it is. Moreover, there is also an alternative which Mackie failed to consider: (iv) prior to creation God existed in an undifferentiated time in which hours, seconds, days, and so forth simply do not exist. Because this time is undifferentiated, it is not incompatible with the *kalām* argument that an infinite regress of events cannot exist. It seems to me, therefore, that Mackie is entirely unjustified in rejecting the first step of the argument as not being intuitively obvious, plausible, and reasonable.

Other critics have said that premise (1) is true only for things *in* the universe, but it is not true *of* the universe itself. But why think that the universe is an excep-

30. Elsewhere Mackie reveals his true sentiments: "I myself find it hard to accept the notion of self-creation *from nothing*, even *given* unrestricted chance. And how *can* this be given, if there really is nothing?" (J. L. Mackie, *Times Literary Supplement*, 5 February 1982, 126).

31. David Hume, *The Letters of David Hume*, 2 vols., ed. J. Y. T. Greig (Oxford: Clarendon, 1932), 1:187.

32. Mackie, *Theism*, 89.

33. See my *Time and Eternity* (Wheaton, Ill.: Crossway, 2001).

tion to the rule? As Arthur Schopenhauer once remarked, the causal principle is not something you can dismiss like a cab once you've arrived at your desired destination. Moreover, the objection misconstrues the nature of the causal principle. Premise (1) does not state a merely physical law like the law of gravity or the laws of thermodynamics, which are valid for things within the universe. Premise (1) is not a physical principle. Rather it is a metaphysical principle: being cannot come from non-being; something cannot come into existence uncaused from nothing. The principle therefore applies to all of reality, and it is thus metaphysically absurd that the universe should pop into being uncaused out of nothing.

Daniel Dennett, misstating the first premise as "Everything that exists must have a cause," accordingly asks, "What caused God?"³⁴ This retort merely caricatures the argument. In fact, apart from certain Enlightenment rationalists, who by "cause" meant merely "sufficient reason," no orthodox theist of any prominence has ever asserted that everything has a cause or that God is self-caused, a notion rightly rejected by Aquinas as metaphysically impossible. Things that *begin to exist* must have causes. In fact, Dennett himself recognizes that a being "outside of time . . . is nothing with an *initiation* or *origin* in need of explanation. What does need its origin explained is the concrete Universe itself."³⁵ Dennett rightly sees that a being which exists eternally, since it never comes into being, has no need of a cause, as do things which have an origin. So Dennett actually affirms the first premise, which will lead him, as we'll see, to the remarkable position that the universe must have caused itself to come into being.

Sometimes it is said that quantum physics furnishes an exception to premise (1), since on the sub-atomic level events are said to be uncaused. In the same way, certain theories of cosmic origins are interpreted as showing that the whole universe could have sprung into being out of the sub-atomic vacuum or even out of nothingness. Thus the universe is said to be the proverbial "free lunch."

This objection, however, is based on misunderstandings. In the first place, not all scientists agree that sub-atomic events are uncaused. A great many physicists today are quite dissatisfied with this view (the so-called Copenhagen Interpretation) of quantum physics and are exploring deterministic theories like that of David Bohm. Thus, quantum physics is not a proven exception to premise (1).³⁶ Second, even on the traditional, indeterministic interpretation, particles do not come into being out of nothing. They arise as spontaneous fluctuations of the energy contained in the sub-atomic vacuum, which constitutes an indeterministic

34. Daniel Dennett, *Breaking the Spell: Religion as a Natural Phenomenon* (New York: Viking, 2006), 242.

35. *Ibid.*, 244.

36. There are at least ten different interpretations of quantum mechanics, many of which are fully deterministic, and no one knows which, if any of these, is correct. Even so determined a naturalist as the physicist Victor Stenger admits, "Other viable interpretations of quantum mechanics remain with no consensus on which, if any, is the correct one"; hence, we have to remain "open to the possibility that causes may someday be found for such phenomena." Victor Stenger, *Has Silence Found God?* (Amherst, N.Y.: Prometheus, 2003), 188–89, 173.

cause of their origination. Third, the same point can be made about theories of the origin of the universe out of a primordial vacuum. Popular magazine articles touting such theories as getting “something from nothing” simply do not understand that the vacuum is not nothing but is a sea of fluctuating energy endowed with a rich structure and subject to physical laws. Such models do not therefore involve a true origination *ex nihilo*.³⁷

Neither do theories such as Alexander Vilenkin’s quantum creation model. Vilenkin invites us to envision a small, closed, spherical universe filled with a so-called false vacuum and containing some ordinary matter. If the radius of such a universe is small, classical physics predicts that it will collapse to a point; but quantum physics permits it to “tunnel” into a state of inflationary expansion. If we allow the radius to shrink all the way to zero, there still remains some positive probability of the universe’s tunneling to inflation. Now Vilenkin equates the initial state of the universe explanatorily prior to tunneling with nothingness. But this equivalence is patently mistaken. As Vilenkin’s own diagram in his recent book illustrates,³⁸ the quantum tunneling is at every point a function from something to something (Fig. 3.1).

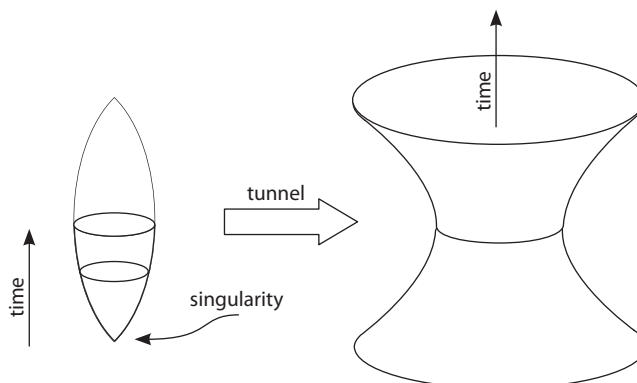

Fig. 3.1: Vilenkin’s model of quantum creation. Note that the tunneling is at every point from something to something; the origin of the initial point remains unexplained.

37. As Kanitscheider explains, “The violent microstructure of the vacuum has been used in attempts to explain the origin of the universe as a long-lived vacuum fluctuation. But some authors have connected with this legitimate speculations [*sic*] far-reaching metaphysical claims, or at most they couched their mathematics in a highly misleading language, when they maintained ‘the creation of the universe out of nothing.’ . . . From the philosophical point of view it is essential to note that the foregoing is far from being a spontaneous generation of everything from naught, but the origin of that embryonic bubble is really a causal process leading from a primordial substratum with a rich physical structure to a materialized substratum of the vacuum. Admittedly this process is not deterministic, it includes that weak kind of causal dependence peculiar to every quantum mechanical process.” Bernulf Kanitscheider, “Does Physical Cosmology Transcend the Limits of Naturalistic Reasoning?” in *Studies on Mario Bunge’s “Treatise,”* ed. Weingartner and G. J. W. Doen (Amsterdam: Rodopi, 1990), 346–74.

38. Alex Vilenkin, *Many Worlds in One: The Search for Other Universes* (New York: Hill and Wang, 2006), 180.

For quantum tunneling to be truly from nothing, the function would have to have only one term, the posterior term. Another way of seeing the point is to reflect on the fact that to have no radius (as is the case with nothingness) is not to have a radius, whose measure is zero. Thus, there is no basis for the claim that quantum physics proves that things can begin to exist without a cause, much less that the universe could have sprung into being uncaused from literally nothing.

That Vilenkin has not truly grasped how radical is being's coming from non-being is evident from his incredulity at the claim of the Hartle-Hawking model that an infinite universe should similarly arise from nothing. He exclaims, "The most probable thing to pop out of nothing is then an infinite, empty, flat space. I find this very hard to believe!"³⁹ Vilenkin finds it easier to believe that an itsy-bitsy universe should pop into being out of nothing. He thereby evinces a lack of understanding of the metaphysical chasm that separates being from non-being. If something can come from nothing, then the size and shape of the object is just irrelevant.

THE UNIVERSE BEGAN TO EXIST

If we agree that whatever begins to exist has a cause, what evidence is there to support the crucial second step in the argument, that the universe began to exist? We'll examine both deductive, philosophical arguments and inductive, scientific arguments in support of (2).

Philosophical Arguments:

1) The Impossibility of an Actually Infinite Number of Things

This argument can also be formulated in three steps:

- 1) An actually infinite number of things cannot exist.
- 2) A beginningless series of events in time entails an actually infinite number of things.
- 3) Therefore, a beginningless series of events in time cannot exist.

Let's examine each premise in turn.

(1) *An actually infinite number of things cannot exist.* In order to understand this first premise, we need to understand what an actual infinite is. There is a difference between a potential infinite and an actual infinite. An actual infinite is a collection of definite and discrete members whose number is greater than any natural number 0, 1, 2, 3 . . . This sort of infinity is used in set theory to designate sets that have an infinite number of members, such as {0, 1, 2, 3 . . .}. The symbol for this kind of infinity is the Hebrew letter aleph: \aleph . The number of members in the set of natural numbers is \aleph_0 . By contrast, a potential infinite is a collection that is increasing toward infinity as a limit but never gets there. The symbol for this kind of infinity is the lemniscate: ∞ . Such a collection is really indefinite, not infinite.

39. Ibid., 191.

For example, any finite distance can be subdivided into potentially infinitely many parts. You can just keep on dividing parts in half forever, but you will never arrive at an actual "infiniteth" division or come up with an actually infinite number of parts. Now premise (1) asserts, not that a potentially infinite number of things cannot exist, but that an actually infinite number of things cannot exist.

It is frequently alleged that this sort of argument has been cut off at the knees by the work of the nineteenth-century mathematician Georg Cantor on the actual infinite and by subsequent developments in set theory, which have legitimized the notion of the actual infinite. But this allegation is far too hasty. It not only begs the question against denials of the mathematical legitimacy of the actual infinite on the part of certain mathematicians (so-called Intuitionists), but, more seriously, it begs the question against anti-realist views of mathematical objects. These are distinct questions, run together by such recent critics of the argument as Howard Sobel and Graham Oppy.⁴⁰ Most anti-realists would not go to the Intuitionistic extreme of denying mathematical legitimacy to the actual infinite—hence, the defiant declaration of the great German mathematician David Hilbert: “No one shall be able to drive us from the paradise that Cantor has created for us.”⁴¹ They would simply insist that acceptance of the mathematical legitimacy of certain notions does not imply a commitment to the metaphysical reality of various objects. In Hilbert’s view, “The infinite is nowhere to be found in reality. It neither exists in nature nor provides a legitimate basis for rational thought. . . . The role that remains for the infinite to play is solely that of an idea.”⁴² Cantor’s system and set theory may be taken to be simply a universe of discourse, a mathematical system based on certain adopted axioms and conventions. On anti-realist views of mathematical objects such as Balaguer’s Fictionalism or Yablo’s Figuralism or Chihara’s Constructibilism, mathematical discourse is not in any way abridged, but there are, notwithstanding, no mathematical objects, let alone an infinite number of them.⁴³ One may consistently hold that while the actual infinite is a fruitful and consistent concept within the postulated universe of discourse, it cannot be transposed into the real world, for this would involve counter-intuitive absurdities.

40. Sobel, *Logic and Theism*, 181–89, 198–99; Graham Oppy, *Philosophical Perspectives on Infinity* (Cambridge: Cambridge University Press, 2006), 291–93.

41. David Hilbert, “On the Infinite,” in *Philosophy of Mathematics*, ed. with an introduction by Paul Benacerraf and Hillary Putnam (Englewood Cliffs, N.J.: Prentice-Hall, 1964), 141.

42. *Ibid.*, 151.

43. Mark Balaguer, *Platonism and Anti-Platonism in Mathematics* (New York: Oxford University Press, 1998), part 2; *idem*, “A Theory of Mathematical Correctness and Mathematical Truth,” *Pacific Philosophical Quarterly* 82 (2001): 87–114; *Stanford Encyclopedia of Philosophy*, s.v. “Platonism in Metaphysics,” by Mark Balaguer (Summer 2004), ed. Edward N. Zalta, <http://plato.stanford.edu/archives/sum2004/entries/platonism/>; Stephen Yablo, “A Paradox of Existence,” in *Empty Names, Fiction, and the Puzzles of Non-Existence*, ed. Anthony Everett and Thomas Hofweber (Stanford: Center for Study of Language and Information, 2000), 275–312; *idem*, “Go Figure: A Path through Fictionalism,” in *Figurative Language*, ed. Peter A. French and Howard K. Wettstein, *Midwest Studies in Philosophy* 25 (Oxford: Blackwell, 2001), 72–102; Charles S. Chihara, *Constructibility and Mathematical Existence* (Oxford: Clarendon, 1990); *idem*, *A Structural Account of Mathematics* (Oxford: Clarendon, 2004).

Ludwig Wittgenstein enunciated perhaps the best strategy for showing the metaphysical impossibility of the actual infinite when he quipped, “I wouldn’t dream of trying to drive anyone from this paradise. I would do something quite different: I would try to show you that it is not a paradise—so that you’ll leave of your own accord. I would say, ‘You’re welcome to this; just look about you.’”⁴⁴ If an actually infinite number of things could exist, this would spawn all sorts of absurdities. We can construct thought experiments illustrating what it would be like if an actually infinite number of things were to exist, in order to evoke a sense of how absurd such a world would be. Let me share one my favorites, Hilbert’s Hotel, the brainchild of David Hilbert.⁴⁵

As a warm-up, let’s first imagine a hotel with a finite number of rooms. Suppose, furthermore, that all the rooms are occupied. When a new guest arrives asking for a room, the proprietor apologizes, “Sorry, all the rooms are full,” and that’s the end of the story. But now let us imagine a hotel with an infinite number of rooms and suppose once more that *all the rooms are occupied*. There is not a single vacant room throughout the entire infinite hotel. Now suppose a new guest shows up, asking for a room. “But of course!” says the proprietor, and he immediately shifts the person in room #1 into room #2, the person in room #2 into room #3, the person in room #3 into room #4, and so on, out to infinity. As a result of these room changes, room #1 now becomes vacant and the new guest gratefully checks in. But remember, before he arrived, all the rooms were already occupied!

But the situation becomes even stranger. For suppose an infinity of new guests shows up at the desk, each asking for a room. “Of course, of course!” says the proprietor, and he proceeds to shift the person in room #1 into room #2, the person in room #2 into room #4, the person in room #3 into room #6, and so on out to infinity, always putting each former occupant into the room with a number twice his own. Because any natural number multiplied by two always equals an even number, all the guests wind up in even-numbered rooms. As a result, all the odd-numbered rooms become vacant, and the infinity of new guests is easily accommodated. And yet, before they came, all the rooms were already occupied! In fact, the proprietor could repeat this process *infinitely many times* and so always accommodate new guests, despite the fact that the hotel is completely full! As one student remarked to me, if Hilbert’s Hotel could exist, it would have to have a sign posted outside: NO VACANCY—GUESTS WELCOME.

But Hilbert’s Hotel is even stranger than the great German mathematician made it out to be. Just ask yourself the question: what happens if some of the guests start to check out? Suppose the guests in rooms #1, #3, #5 . . . check out. In this case an infinite number of people has left the hotel, and half the rooms are now empty.

44. Ludwig Wittgenstein, *Lectures on the Foundations of Mathematics*, ed. Cora Diamond (Sussex, England: Harvester, 1976), 103.

45. The story of Hilbert’s Hotel is related in George Gamow, *One, Two, Three, Infinity* (London: Macmillan, 1946), 17.

Now suppose the proprietor doesn't like having a half-empty hotel (it looks bad for business). No matter! By shifting occupants as before, but in reverse order, he transforms his half-vacant hotel into one that is jammed to the gills! You might think that by such maneuvers the proprietor could always keep this strange hotel fully occupied. But you would be wrong. For suppose that the persons in rooms #4, #5, #6 . . . checked out. At a single stroke the hotel would be virtually emptied, the guest register reduced to but three names, and the infinite converted to finitude. And yet it would remain true that the *same number* of guests checked out this time as when the guests in rooms #1, #3, #5 . . . checked out! In both cases we subtracted the *identical number* of guests from the *identical number* of guests and yet did not arrive at an identical result. In fact one can subtract equal quantities from equal quantities and get any quantity between zero and infinity as the remainder. Can anyone believe that such a hotel could exist in reality?

Hilbert's Hotel is absurd. Since nothing hangs on the illustration's involving a hotel, the argument, if successful, would show in general that it is impossible for an actually infinite number of things to exist. Students sometimes react to such illustrations as Hilbert's Hotel by saying that we don't understand the nature of infinity and, hence, these absurdities result. But this attitude is simply mistaken. Infinite set theory is a highly developed and well-understood branch of mathematics, and these absurdities can be seen to result precisely because we *do* understand the notion of a collection with an actually infinite number of members. Hilbert's illustration merely serves to bring out in a practical and vivid way what the mathematics necessarily implies; for if an actually infinite number of things were possible, then such a hotel must be possible. Hence, it logically follows that if such a hotel is impossible, then so is the real existence of an actual infinite.⁴⁶

What can the argument's critic say at this point? Mackie, Sobel, and Oppy try, in Oppy's words, to "outsmart" the proponent of the argument by embracing the conclusion of his *reductio ad absurdum* argument: Hilbert's Hotel is possible after all.⁴⁷ The problem with this strategy is that it could be used to legitimize any conclusion, no matter how absurd, so long as one has the chutzpah to embrace it. What we want is some sort of reason to think that such a hotel is really possible. Here Oppy has no more to say than "these allegedly absurd situations are just what one ought to expect if there were . . . physical infinities." This response only reiterates, in effect, that if an actual infinite were to exist, then the relevant situations would result, which is not in dispute. The situations would, after all, not be effective illustrations if they would not result! Rather the question is whether these situations really are absurd. It is indisputable that if an actually infinite number of things

46. Students frequently ask if God, therefore, cannot be infinite. The question is based on a misunderstanding. When we speak of the infinity of God, we are not using the word in a mathematical sense to refer to an aggregate of an infinite number of finite parts. God's infinity is, if you will, qualitative, not quantitative. It means that God is metaphysically necessary, morally perfect, omnipotent, omniscient, eternal, etc.

47. Graham Oppy, *Philosophical Perspectives on Infinity*, 48; cf. Mackie, *Theism*, 93; Sobel, *Logic and Theism*, 186–87.

were to exist, then we should find ourselves landed in an Alice-in-Wonderland world populated with oddities like Hilbert's Hotel. Merely reiterating that "If there were physical infinities, these situations are just what we ought to expect" does nothing to allay one's suspicions that such a world is metaphysically absurd. Moreover, Oppy says nothing about what would happen in cases of inverse operations like subtraction with infinite quantities, as when an infinite number of guests check out of the hotel. In trans-finite arithmetic, inverse operations of subtraction and division are prohibited because they lead to contradictions; but in reality, one cannot stop people from checking out of the hotel if they so desire!

Again, it's worth reiterating that nothing in the argument need be construed as an attempt to undermine the theoretical system bequeathed by Cantor to modern mathematics. Indeed, some of the most eager enthusiasts of the system of transfinite mathematics are only too ready to agree that these theories have no relation to the real world. The case against the real existence of the actual infinite says nothing about the use of the idea of the infinite in conceptual mathematical systems.

2) *A beginningless series of events in time entails an actually infinite number of things.* This second premise is pretty obvious. If the universe never began to exist, then prior to the present event there have existed an actually infinite number of previous events. Thus, a beginningless series of events in time entails an actually infinite number of things, namely, events.

3) *Therefore, a beginningless series of events in time cannot exist.* If the above two premises are true, then the conclusion follows logically. The series of past events must be finite and have a beginning. Since the universe is not distinct from the series of events, the universe therefore began to exist.

Philosophical Arguments:

(2) *The Impossibility of Forming an Actually Infinite Collection of Things by Adding One Member after Another*

It's important to note that this second argument is distinct from the foregoing argument, for it does not deny that an actually infinite number of things can exist. It denies that a collection containing an actually infinite number of things can be *formed* by adding one member after another. So even if the first philosophical argument were deemed to be unsound, the critic of the *kalām* cosmological argument must still contend with this independent argument for the second premise. This argument, too, can be formulated in three steps:

- 1) The series of events in time is a collection formed by adding one member after another.
- 2) A collection formed by adding one member after another cannot be actually infinite.
- 3) Therefore, the series of events in time cannot be actually infinite.

Let's take a look at each premise.

1) *The series of events in time is a collection formed by adding one member after another.* This may seem rather obvious. The past did not spring into being whole and entire but was formed sequentially, one event occurring after another. Notice, too, that the direction of this formation is “forward,” in the sense that the collection grows with time. Although we sometimes speak of an “infinite regress” of events, in reality an infinite past would be an “infinite progress” of events with no beginning and its end in the present.

As obvious as this first premise may seem at first blush, it is, in fact, a matter of great controversy. It presupposes a certain view of time which is variously called the tensed or dynamic or, following the convenient nomenclature of J. M. E. McTaggart, who first distinguished these views of time, the A-Theory of time. According to the A-Theory, things/events in time are not all equally real: the future does not yet exist and the past no longer exists; only things which are present are real. Temporal becoming is an objective feature of reality: things come into being and go out of being. By contrast, on what McTaggart called the B-Theory of time or the tenseless or static theory of time all events in time are equally real, and temporal becoming is an illusion of human consciousness. *Pastness*, *presentness*, and *futurity* are at most relative notions: for example, relative to the persons living in the year 2050 the people and events of 2000 are past, but relative to the persons living in 1950 the people and events of 2000 are future. Things and events in time are objectively ordered by the relations *earlier than*, *simultaneous with*, and *later than*, which are tenseless relations that are unchanging and hold regardless of whether the related events are past, present, or future relative to some observer. B-Theorists typically unify time with space into a four-dimensional, geometrical entity called spacetime, all of whose points are equally real and none of which is objectively present. On a B-Theory of time, premise (1) is false, for the past, like the future, exists tenselessly and there is no question of the series of events’ being formed sequentially.

The question, then, is which of these two competing theories of time is true? Unfortunately, an adjudication of this issue here would take us too far afield. Everyone agrees that the commonsense view is that the difference between past, present, and future is real and objective, and as a result of over a decade of intensive research on this question my studied opinion is that there is no reason to abandon the commonsense view of this matter.⁴⁸ Therefore, I am convinced that the A-Theory of time is correct and, accordingly, that premise (1) is true. Given that the vast majority of people share this conviction, I think that an argument based upon this premise will provoke little objection on this score.

2) *A collection formed by adding one member after another cannot be actually infinite.* This is the crucial step. It’s important to realize that this impossibility has nothing to do with the amount of time available: no matter how much time one

48. See my *Time and Eternity* for a consideration of the arguments for and against these theories of time and my defense of the A-Theory.

has available, an actual infinite cannot be formed. This may seem obvious in the case of someone's trying to count to infinity: no matter how many numbers he counts, he can always add one more before arriving at infinity. Now someone might say that while an infinite collection cannot be formed by beginning at a point and adding members, nevertheless, an infinite collection could be formed by never beginning but ending at a point, that is to say, ending at a point after having added one member after another from eternity. But this method seems even more unbelievable than the first method. If one cannot count to infinity, how can one count down from infinity?

Sometimes this problem is described as the impossibility of traversing the infinite. In order for us to have "arrived" at today, temporal existence has, so to speak, traversed an infinite number of prior events. Richard Gale protests, "This argument depends on an anthropomorphic sense of 'going through' a set. The universe does not go through a set of events in the sense of planning which to go through first, in order to get through the second, and so on."⁴⁹ Of course not; but on an A-Theory of time the universe does endure through successive intervals of time. It arrives at its present event-state only by enduring through a series of prior event-states. So before the present event could occur, the event immediately prior to it would have to occur; and before that event could occur, the event immediately prior to it would have to occur; and so on *ad infinitum*. So one gets driven back and back into the infinite past, making it impossible for any event to occur. Thus, if the series of past events were beginningless, the present event could not have occurred, which is absurd.

Sometimes critics indict this argument as a slight-of-hand trick like Zeno's paradoxes of motion. Zeno argued that before Achilles could cross the stadium, he would have to cross halfway; but before he could cross halfway, he would have to cross a quarter of the way; but before he could cross a quarter of the way, he would have to cross an eighth of the way, and so on to infinity. It is evident that Achilles could not arrive at any point! Therefore, Zeno concluded, motion is impossible. Now even though Zeno's argument is very difficult to refute, nobody really believes that motion is impossible. Even if Achilles must pass through an infinite number of halfway points in order to cross the stadium, somehow he manages to do so. The argument against the impossibility of traversing an infinite past, some critics allege, must commit the same fallacy as Zeno's paradox.

But such an objection fails to reckon with two crucial disanalogies of an infinite past to Zeno's paradoxes: whereas in Zeno's thought experiments the intervals traversed are *potential* and *unequal*, in the case of an infinite past the intervals are *actual* and *equal*. The claim that Achilles must pass through an infinite number

49. Richard Gale, "The Failure of Classic Theistic Arguments," in *The Cambridge Companion to Atheism*, ed. Michael Martin, Cambridge Companions to Philosophy (Cambridge: Cambridge University Press, 2007), 92–93. Gale's framing the argument in terms of a "set of events" is maladroit, since we are not talking about a set but about a series of events which elapse one after another. Cf. Russell's statement cited below (n. 52).

of halfway points in order to cross the stadium is question-begging, for it already assumes that the whole interval is a composition of an infinite number of points, whereas Zeno's opponents, like Aristotle, take the line as a whole to be conceptually prior to any divisions which we might make in it. Moreover, Zeno's intervals, being unequal, sum to a merely finite distance, whereas the intervals in an infinite past sum to an infinite distance. Thus, his thought experiments are crucially dis-analogous to the task of traversing an infinite number of equal, actual intervals to arrive at our present location.

Mackie and Sobel object that this sort of argument illicitly presupposes an infinitely distant starting point in the past and then pronounces it impossible to travel from that point to today. But if the past is infinite, they say, then there would be no starting point whatever, not even an infinitely distant one. Nevertheless, from any given point in the past, there is only a finite distance to the present, which is easily "traversed."⁵⁰ But in fact no proponent of the *kalām* argument of whom I am aware has assumed that there was an infinitely distant starting point in the past. The fact that there is *no beginning* at all, not even an infinitely distant one, seems only to make the problem worse, not better. To say that the infinite past could have been formed by successive addition is like saying that someone has just succeeded in writing down all the negative numbers, ending at 0. And, we may ask, how is the claim that from any given moment in the past there is only a finite distance to the present even relevant to the issue? The defender of the *kalām* argument could agree to this happily. For the issue is how the *whole* series can be formed, not a finite portion of it. Do Mackie and Sobel think that because every *finite* segment of the series can be formed by successive addition the whole *infinite* series can be so formed? That is as logically fallacious as saying because every part of an elephant is light in weight, the whole elephant is light in weight. The claim is therefore irrelevant.

We can heighten the absurdity of the sequential formation of an actual infinite by imagining, with al-Ghāzali, two beginningless series of coordinated events. He envisions our solar system's existing from eternity past, the orbital periods of the planets being so coordinated that for every one orbit which Saturn completes Jupiter completes 2.5 times as many. If they have been orbiting from eternity, which planet has completed the most orbits? The correct mathematical answer is that they have completed precisely the same number of orbits. But this seems absurd, for the longer they revolve the greater becomes the disparity between them, so that they progressively approach a limit at which Jupiter has fallen infinitely far behind Saturn. Yet, being now actually infinite, their respective completed orbits are somehow magically identical. Indeed, they will have "attained" infinity from eternity past: the number of completed orbits is always the same. Moreover, Ghāzali asks, will the number of completed orbits be even or odd? Either answer seems absurd. We might be tempted to deny that the number of completed or-

50. Mackie, *Theism*, 93; Sobel, *Logic and Theism*, 182.

bits is either even or odd. But post-Cantorian transfinite arithmetic gives a quite different answer: the number of orbits completed is both even and odd!⁵¹ For a cardinal number n is even if there is a unique cardinal number m such that $n = 2m$, and n is odd if there is a unique cardinal number m such that $n = 2m + 1$. In the envisioned scenario the number of completed orbits is (in both cases!) \aleph_0 , and $\aleph_0 = 2\aleph_0 = 2\aleph_0 + 1$. So Jupiter and Saturn have each completed both an even and an odd number of orbits, and that number has remained equal and unchanged from all eternity, despite their ongoing revolutions and the growing disparity between them over any finite interval of time. This strikes me as absurd.

It gets even worse. Suppose we meet a man who claims to have been counting down from infinity and who is now finishing: . . . , -3, -2, -1, 0. We could ask, why didn't he finish counting yesterday or the day before or the year before? By then an infinite time had already elapsed, so that he should already have finished. Thus, at no point in the infinite past could we ever find the man finishing his countdown, for by that point he should already be done! In fact, no matter how far back into the past we go, we can never find the man counting at all, for at any point we reach he will already have finished. But if at no point in the past do we find him counting, this contradicts the hypothesis that he has been counting from eternity. This shows again that the formation of an actual infinite by never beginning but reaching an end is as impossible as beginning at a point and trying to reach infinity.

Hence, set theory has been purged of all temporal concepts; as Russell says, "Classes which are infinite are given all at once by the defining properties of their members, so that there is no question of 'completion' or of 'successive synthesis.'"⁵² The only way an actual infinite could come to exist in the real world would be by being created all at once, simply in an instant. It would be a hopeless undertaking to try to form it by adding one member after another.

3) *Therefore, the series of events in time cannot be actually infinite.* Given the truth of the premises, the conclusion logically follows. If the universe did not begin to exist a finite time ago, then the present moment would never arrive. But obviously it has arrived. Therefore, we know that the universe is finite in the past and began to exist.

We thus have two separate philosophical arguments to prove that the universe began to exist, one based on the impossibility of an actually infinite number of things and one on the impossibility of forming an actually infinite collection by successive addition. If one wishes to deny the beginning of the universe, he must refute, not one, but both of these arguments.

51. See Wacław Sierpiński, *Cardinal and Ordinal Numbers*, Polska Akademia Nauk Monografie Matematyczne 34 (Warsaw: Państwowe Wydawnictwo Naukowe, 1958), 146.

52. Bertrand Russell, *Our Knowledge of the External World*, 2nd ed. (New York: W. W. Norton, 1929), 170.

*Scientific Arguments:**(3) The Expansion of the Universe*

Now some people find philosophical arguments dubious or difficult to follow; they prefer empirical evidence. So I now turn to an examination of two remarkable scientific confirmations of the conclusion already reached by philosophical argument alone. Before I do so, however, I want to note in passing that the sort of philosophical problems with the infinity of the past which we have discussed are now being recognized in scientific papers by leading cosmologists and philosophers of science.⁵³ For example, Ellis, Kirchner, and Stoeger ask, “Can there be an infinite set of really existing universes? We suggest that, on the basis of well-known *philosophical* arguments, the answer is No.”⁵⁴ Similarly, noting that an actual infinite is not constructible and therefore not actualizable, they assert, “This is precisely why a realised past infinity in time is not considered possible from this standpoint—since it involves an infinite set of completed events or moments.”⁵⁵ These misgivings represent endorsements of both of the *kalām* arguments which I defended above. Ellis and his colleagues conclude, “The arguments against an infinite past time are strong—it’s simply not constructible in terms of events or instants of time, besides being conceptually indefinite.”⁵⁶

The physical evidence for the expansion of the universe comes from what is undoubtedly one of the most exciting and rapidly developing fields of science today: astronomy and astrophysics. Prior to the 1920s, scientists had always assumed that the universe was stationary and eternal. Tremors of the impending earthquake that would topple this traditional cosmology were first felt in 1917, when Albert Einstein made a cosmological application of his newly discovered gravitational theory, the General Theory of Relativity (GR). To his chagrin, Einstein found that GR would not permit an eternal, static model of the universe unless he fudged the equations in order to offset the gravitational effect of matter. As a result Einstein’s universe was balanced on a razor’s edge, and the least perturbation—even the transport of matter from one part of the universe to another—would cause the universe either to implode or to expand. By taking this feature of Einstein’s model seriously, the Russian mathematician Alexander Friedman and the Belgian astronomer Georges Lemaître were able to formulate independently in the 1920s solutions to his equations which predicted an expanding universe.

The monumental significance of the Friedman-Lemaître model lay in its historicization of the universe. As one commentator has remarked, up to this time the idea of the expansion of the universe “was absolutely beyond comprehension. Throughout

53. Besides the paper by Ellis et al. cited below, see also Rüdiger Vaas, “Time before Time: Classifications of Universes in contemporary cosmology, and how to avoid the antinomy of the beginning and eternity of the world,” <http://arXiv.org/abs/physics/0408111> (2004).

54. G. F. R. Ellis, U. Kirchner, and W. R. Stoeger, “Multiverses and Physical Cosmology,” <http://arXiv:astro-ph/0305292> v3 (28 August 2003), 14 (my emphasis).

55. *Ibid.*

56. *Ibid.*

all of human history the universe was regarded as fixed and immutable and the idea that it might actually be changing was inconceivable.⁵⁷ But if the Friedman-Lemaître model were correct, the universe could no longer be adequately treated as a static entity existing, in effect, timelessly. Rather the universe has a history, and time will not be matter of indifference for our investigation of the cosmos.

In 1929 the American astronomer Edwin Hubble showed that the light from distant galaxies is systematically shifted toward the red end of the spectrum. This red-shift was taken to be a Doppler effect indicating that the light sources were receding in the line of sight. Incredibly, what Hubble had discovered was the expansion of the universe predicted by Friedman and Lemaître on the basis of Einstein's GR. It was a veritable turning point in the history of science. "Of all the great predictions that science has ever made over the centuries," exclaims John Wheeler, "was there ever one greater than this, to predict, and predict correctly, and predict against all expectation a phenomenon so fantastic as the expansion of the universe?"⁵⁸

The Standard Model

According to the Friedman-Lemaître model, as time proceeds, the distances separating the galaxies become greater. It's important to appreciate that as a GR-based theory, the model does not describe the expansion of the material content of the universe into a preexisting, empty space, but rather the expansion of space itself. The galaxies are conceived to be at rest with respect to space but to recede progressively from one another as space itself expands or stretches, just as buttons glued to the surface of a balloon will recede from one another as the balloon inflates. As the universe expands, it becomes less and less dense. This has the astonishing implication that as one reverses the expansion and extrapolates back in time, the universe becomes progressively denser until one arrives at a state of infinite density at some point in the finite past. This state represents a singularity at which spacetime curvature, along with temperature, pressure, and density, becomes infinite. It therefore constitutes an edge or boundary to spacetime itself. P. C. W. Davies comments,

If we extrapolate this prediction to its extreme, we reach a point when all distances in the universe have shrunk to zero. An initial cosmological singularity therefore forms a past temporal extremity to the universe. We cannot continue physical reasoning, or even the concept of spacetime, through such an extremity. For this reason most cosmologists think of the initial singularity as the beginning of the universe. On this view the big bang represents the creation event; the creation not only of all the matter and energy in the universe, but also of spacetime itself.⁵⁹

57. Gregory L. Naber, *Spacetime and Singularities: an Introduction* (Cambridge: Cambridge University Press, 1988), 126–27.

58. John A. Wheeler, "Beyond the Hole," in *Some Strangeness in the Proportion*, ed. Harry Woolf (Reading, Mass.: Addison-Wesley, 1980), 354.

59. P. C. W. Davies, "Spacetime Singularities in Cosmology," in *The Study of Time III*, ed. J. T. Fraser (Berlin: Springer Verlag, 1978), 78–79.

The term “Big Bang,” originally a derisive expression coined by Fred Hoyle to characterize the beginning of the universe predicted by the Friedman-Lemaître model, is thus potentially misleading, since the expansion cannot be visualized from the outside (there being no “outside,” just as there is no “before” with respect to the Big Bang).⁶⁰

The standard Big Bang model, as the Friedman-Lemaître model came to be called, thus describes a universe which is not eternal in the past, but which came into being a finite time ago. Moreover—and this deserves underscoring—the origin it posits is an absolute origin out of nothing. For not only all matter and energy, but space and time themselves come into being at the initial cosmological singularity. As physicists John Barrow and Frank Tipler emphasize, “At this singularity, space and time came into existence; literally nothing existed before the singularity, so, if the Universe originated at such a singularity, we would truly have a creation *ex nihilo*.”⁶¹ Thus, we may graphically represent spacetime as a cone (Fig. 3.2).

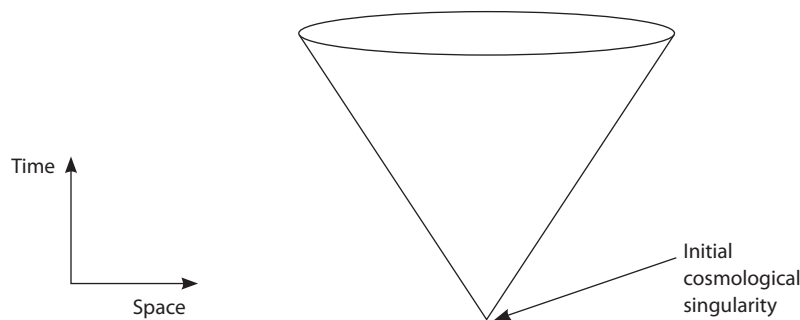

Fig. 3.2: Conical representation of Standard Model spacetime. Space and time begin at the initial cosmological singularity, before which literally nothing exists.

60. As Gott, Gunn, Schramm, and Tinsley write: “The universe began from a state of infinite density about one Hubble time ago. Space and time were created in that event and so was all the matter in the universe. It is not meaningful to ask what happened before the big bang; it is somewhat like asking what is north of the North Pole. Similarly, it is not sensible to ask where the big bang took place. The point-universe was not an object isolated in space; it was the entire universe, and so the only answer can be that the big bang happened everywhere.” J. Richard Gott III, James E. Gunn, David N. Schramm, and Beatrice M. Tinsley, “Will the Universe Expand Forever?” *Scientific American*, March 1976, 65.

The Hubble time is the time since the singularity if the rate of expansion has been constant. The singularity is a point only in the sense that the distance between any two points in the singularity is zero. Anyone who thinks that there must be a place in the universe where the Big Bang occurred still has not grasped that it is space itself which is expanding; it is the two-dimensional *surface* of an inflating balloon which is analogous to three-dimensional space. The spherical surface has no center and so no location where the expansion begins. The analogy of the North Pole with the beginning of time should not be pressed, since the North Pole is not an edge to the surface of the globe; the beginning of time is more like the apex of a cone. But the idea is that just as one cannot go further north than the North Pole, so one cannot go earlier than the initial singularity.

61. John Barrow and Frank Tipler, *The Anthropic Cosmological Principle* (Oxford: Clarendon, 1986), 442.

On such a model the universe originates *ex nihilo* in the sense that at the initial singularity it is true that *there is no earlier spacetime point* or it is false that *something existed prior to the singularity*.

Now such a conclusion is profoundly disturbing for anyone who ponders it. For the question cannot be suppressed: *why did the universe come into being?* Sir Arthur Eddington, contemplating the beginning of the universe, opined that the expansion of the universe was so preposterous and incredible that “I feel almost an indignation that anyone should believe in it—except myself.”⁶² He finally felt forced to conclude, “The beginning seems to present insuperable difficulties unless we agree to look on it as frankly supernatural.”⁶³ The problem of the origin of the universe, in the words of one astrophysical team, thus “involves a certain metaphysical aspect which may be either appealing or revolting.”⁶⁴

The Steady State Model

Revolted by the stark metaphysical alternatives presented by an absolute beginning of the universe, certain theorists have been understandably eager to subvert the Standard Model and restore an eternal universe. The first such attempt came in 1948 with the first competitor to the Standard Model, namely, the Steady State Model of the universe. According to this theory, the universe is in a state of cosmic expansion, but as the galaxies recede, new matter is drawn into being *ex nihilo* in the voids created by the galactic recession (Fig. 3.3).

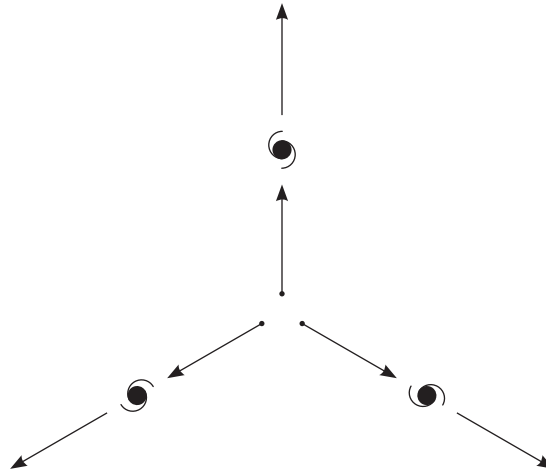

Fig. 3.3: Steady State Model. As the galaxies mutually recede, new matter comes into existence to replace them. The universe thus constantly renews itself and so never began to exist.

62. Arthur Eddington, *The Expanding Universe* (New York: Macmillan, 1933), 124.

63. *Ibid.*, 178.

64. Hubert Reeves, Jean Audouze, William A. Fowler, and David N. Schramm, “On the Origin of Light Elements,” *Astrophysical Journal* 179 (1973): 912.

If one extrapolates the expansion of the universe back in time, the density of the universe never increases because the matter and energy simply vanish as the galaxies mutually approach!

The Steady State theory never secured a single piece of experimental verification; its appeal was purely metaphysical. Instead, observational astronomy made it increasingly evident that the universe had an evolutionary history. But the decisive refutation of the Steady State Model came with two discoveries which constituted, in addition to the galactic red-shift, the most significant evidence for the Big Bang theory: the primordial nucleosynthesis of the light elements and the microwave background radiation. Although the heavy elements were synthesized in the stars, stellar nucleosynthesis could not manufacture the abundant light elements such as helium and deuterium. These could only have been created in the extreme conditions present in the first moment of the Big Bang. In 1965 a serendipitous discovery revealed the existence of a cosmic background radiation predicted in the 1940s by George Gamow on the basis of the Standard Model. This radiation, now shifted into the microwave region of the spectrum, consists of photons emitted during a very hot and dense phase of the universe. In the minds of most cosmologists, the cosmic background radiation decisively discredited the Steady State Model.

Oscillating Models

The Standard Model was based on the assumption that the universe is largely the same in every direction. In the 1960s and 1970s some cosmologists suggested that by denying that assumption, one might be able to craft an Oscillating Model of the universe and thus avert the absolute beginning predicted by the Standard Model. If the internal gravitational pull of the mass of the universe were able to overcome the force of its expansion, then the expansion could be reversed into a cosmic contraction, a Big Crunch. If the matter of the universe were not evenly distributed, then the collapsing universe might not coalesce at a point, but quantities of matter might pass by one another, so that the universe would appear to bounce back from the contraction into a new expansion phase. If this process could be repeated indefinitely, then an absolute beginning of the universe might be avoided (Fig. 3.4).

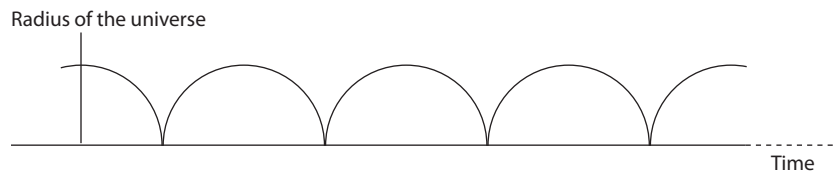

Fig. 3.4: Oscillating Model. Each expansion phase is preceded and succeeded by a contraction phase, so that the universe in concertina-like fashion exists beginninglessly and endlessly.

Such a theory is extraordinarily speculative, but again there were metaphysical motivations for adopting this model. The prospects of the Oscillating Model were

severely dimmed in 1970, however, by Roger Penrose and Stephen Hawking's formulation of the Singularity Theorems which bear their names. The theorems disclosed that under very generalized conditions an initial cosmological singularity is inevitable, even for inhomogeneous universes. Reflecting on the impact of this discovery, Hawking notes that the Hawking-Penrose Singularity Theorems "led to the abandonment of attempts (mainly by the Russians) to argue that there was a previous contracting phase and a non-singular bounce into expansion. Instead almost everyone now believes that the universe, and time itself, had a beginning at the big bang."⁶⁵

Despite the fact that no spacetime trajectory can be extended through a singularity, the Oscillating Model exhibited a stubborn persistence. Two further strikes were lodged against it. First, there are no known physics which would cause a collapsing universe to bounce back to a new expansion. If, in defiance of the Hawking-Penrose Singularity Theorems, the universe rebounds, this is predicated upon a physics which is as yet unknown. Second, attempts by observational astronomers to discover the mass density sufficient to generate the gravitational attraction required to halt and reverse the expansion continually came up short. In January of 1998 astronomical teams from Princeton, Yale, the Lawrence Berkeley National Laboratory, and the Harvard-Smithsonian Astrophysics Institute reported at the American Astronomical Society meeting that their various tests all showed that "the universe will expand forever."⁶⁶ A spokesman for the Harvard-Smithsonian team stated that they were now at least 95 percent certain that "the density of matter is insufficient to halt the expansion of the universe."⁶⁷

At the same time, observations of the red-shifts of supernovae yielded unexpected results that have thrown the discussion of the universe's fate into a wholly new arena and served to render questions of its density irrelevant. The red-shift data gathered from the distant supernovae indicate that, far from decelerating, the cosmic expansion is actually accelerating! There is some sort of mysterious "dark energy" in the form of either a variable energy field (called "quintessence") or, more probably, a positive cosmological constant or vacuum energy which at a certain point in the evolution of the cosmos kicks the expansion into a higher gear, causing the expansion to proceed more rapidly. Consequently, even high density universes may expand forever; a potentially infinite future is no longer the privileged prerogative of low density universes. Highly accurate recent measurements of the cosmic microwave background radiation by the Wilkinson Microwave Anisotropy Probe (WMAP) indicate, "For the theory that fits our data, the Universe will expand forever."⁶⁸

65. Stephen Hawking and Roger Penrose, *The Nature of Space and Time*, The Isaac Newton Institute Series of Lectures (Princeton, N.J.: Princeton University Press, 1996), 20.

66. Associated Press News Release, January 9, 1998.

67. Ibid.

68. See http://map.gsfc.nasa.gov/m_mm/mr_limits.html.

Vacuum Fluctuation Models

Physicists realized that a physical description of the universe prior to the Planck time (10^{-43} second after the Big Bang singularity) would require the introduction of quantum physics in addition to GR. On the sub-atomic level so-called virtual particles are thought to arise due to fluctuations in the energy locked up in the vacuum, particles which the Heisenberg Indeterminacy Principle allows to exist for a fleeting moment before dissolving back into the vacuum. In 1973 Edward Tryon speculated whether the universe might not be a long-lived virtual particle, whose total energy is zero, born out of the primordial vacuum. This seemingly bizarre speculation gave rise to a new generation of cosmogonic theories which we may call Vacuum Fluctuation Models. These models were closely related to an adjustment to the Standard Model known as Inflation. In an attempt to explain the astonishing large-scale smoothness of the universe, certain theorists proposed that between 10^{-35} and 10^{-33} second after the Big Bang singularity, the universe underwent a phase of super-rapid, or inflationary, expansion which served to push the inhomogeneities out beyond our event horizon. Prior to the inflationary era the universe was merely empty space, or a vacuum, and the material universe was born when the vacuum energy was converted into matter via a quantum mechanical phase transition. In most inflationary models, as one extrapolates backward in time, beyond the Planck time, the universe continues to shrink down to the initial singularity. But in Vacuum Fluctuation Models, it was hypothesized that prior to inflation the Universe-as-a-whole was not expanding. This Universe-as-a-whole is a primordial vacuum which exists eternally in a steady state. Throughout this vacuum sub-atomic energy fluctuations constantly occur, by means of which matter is created and mini-universes are born (Fig. 3.5).

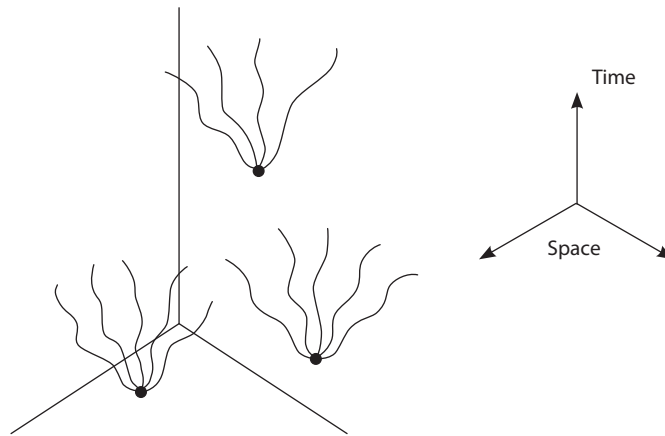

Fig. 3.5: Vacuum Fluctuation Models. Within the vacuum of the wider Universe, fluctuations occur which grow into mini-universes. Ours is but one of these, and its relative beginning does not imply a beginning for the Universe-as-a-whole.

Our expanding universe is but one of an indefinite number of mini-universes conceived within the womb of the greater Universe-as-a-whole. Thus, the beginning of our universe does not represent an absolute beginning, but merely a change in the eternal, uncaused Universe-as-a-whole.

Vacuum Fluctuation Models did not outlive the decade of the 1980s. Not only were there theoretical problems with the production mechanisms of matter, but these models faced a deep internal incoherence. According to such models, it is impossible to specify precisely when and where a fluctuation will occur in the primordial vacuum which will then grow into a universe. Within any finite interval of time there is a positive probability of such a fluctuation's occurring at any point in space. Thus, given infinite past time, universes will eventually be spawned at *every* point in the primordial vacuum, and, as they expand, they will begin to collide and coalesce with one another. Thus, given infinite past time, we should by now be observing an infinitely old universe, not a relatively young one. One theorist tried to avoid this problem by stipulating that fluctuations in the primordial vacuum only occur infinitely far apart, so that each mini-universe has infinite room in which to expand.⁶⁹ Not only is such a scenario unacceptably ad hoc, but it doesn't even solve the problem. For given infinite past time, each of the infinite regions of the vacuum will have spawned an open universe which by now will have entirely filled that region, with the result that all of the individual mini-universes would have coalesced.

About the only way to avert the problem would be to postulate an expansion of the primordial vacuum itself; but then we're right back to the absolute origin implied by the Standard Model. According to quantum cosmologist Christopher Isham these models were therefore jettisoned long ago and "nothing much" has been done with them since.⁷⁰

Chaotic Inflationary Model

Inflation also forms the context for the next alternative: the Chaotic Inflationary Model. Inflationary theory, though criticized by some as unduly "metaphysical," has been widely accepted among cosmologists. One of the most fertile of the inflation theorists has been the Russian cosmologist Andrei Linde, who has championed his Chaotic Inflationary Model.⁷¹ In Linde's model inflation *never* ends: each inflating domain of the universe when it reaches a certain volume gives rise via inflation to another domain, and so on, *ad infinitum* (Fig. 3.6).

69. J. R. Gott III, "Creation of Open Universes from de Sitter Space," *Nature* 295 (1982): 304–7. One might also try to avoid the difficulty of coalescing universes by holding that the mini-universes break off from the mother universe to become separate worlds. But see pp. 145–46.

70. Christopher Isham, "Quantum Cosmology and the Origin of the Universe," lecture presented at the conference "Cosmos and Creation," Cambridge University, July 14, 1994.

71. See, e.g., A. D. Linde, "The Inflationary Universe," *Reports on Progress in Physics* 47 (1984): 925–86; idem, "Chaotic Inflation," *Physics Letters* 1298 (1983): 177–81. For a critical review of inflationary scenarios, including Linde's, see John Earman and Jesus Mosterin, "A Critical Look at Inflationary Cosmology," *Philosophy of Science* 66 (1999): 1–49.

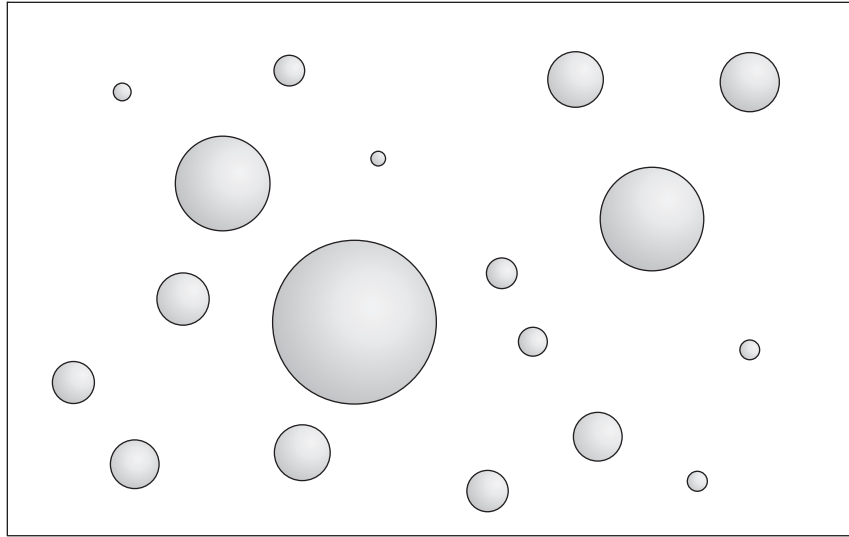

Fig. 3.6: Chaotic Inflationary Model. The wider universe produces via inflation separate domains which continue to recede from one another as the wider space expands.

Linde's model thus has an infinite future. But Linde is troubled at the prospect of an absolute beginning. He writes, "The most difficult aspect of this problem is not the existence of the singularity itself, but the question of what was *before* the singularity. . . . This problem lies somewhere at the boundary between physics and metaphysics."⁷² Linde therefore proposed that chaotic inflation is not only endless, but beginningless. Every domain in the universe is the product of inflation in another domain, so that the singularity is averted and with it as well the question of what came before (or, more accurately, what caused it). Our observable universe turns out to be but one bubble in a wider, eternal multiverse of worlds.

In 1994, however, Arvind Borde and Alexander Vilenkin showed that any space-time eternally inflating toward the future cannot be "geodesically complete" in the past, that is to say, there must have existed at some point in the indefinite past an initial singularity. Hence, the multiverse scenario cannot be past eternal. They write:

A model in which the inflationary phase has no end . . . naturally leads to this question: Can this model also be extended to the infinite past, avoiding in this way the problem of the initial singularity? . . . This is in fact not possible in future-eternal inflationary spacetimes as long as they obey some reasonable physical conditions: such models must necessarily possess initial singularities. . . . The fact that inflationary spacetimes are past incomplete forces one to address the question of what, if anything, came before.⁷³

72. Linde, "Inflationary Universe," 976.

73. A. Borde and A. Vilenkin, "Eternal Inflation and the Initial Singularity," *Physical Review Letters* 72 (1994): 3305, 3307.

In response, Linde concurred with the conclusion of Borde and Vilenkin: there must have been a Big Bang singularity at some point in the past.⁷⁴

In 2003 Borde and Vilenkin in cooperation with Alan Guth were able to strengthen their conclusion by crafting a new theorem independent of the assumption of the so-called “weak energy condition,” which partisans of past-eternal inflation might have denied in an effort to save their theory.⁷⁵ The new theorem, in Vilenkin’s words, “appears to close that door completely.”⁷⁶ Inflationary models, like their predecessors, thus failed to avert the beginning predicted by the Standard Model.

Quantum Gravity Models

At the close of their analysis of Linde’s Chaotic Inflationary Model, Borde and Vilenkin say with respect to Linde’s metaphysical question, “The most promising way to deal with this problem is probably to treat the Universe quantum mechanically and describe it by a wave function rather than by a classical spacetime.”⁷⁷ For “it follows from the theorem that the inflating region has a boundary in the past, and some new physics (other than inflation) is necessary to determine the conditions of that boundary. Quantum cosmology is the prime candidate for this role.”⁷⁸ They thereby bring us to the next class of models which we shall consider, namely, Quantum Gravity Models.

Vilenkin and, more famously, James Hartle and Stephen Hawking have proposed models of the universe which Vilenkin candidly calls exercises in “metaphysical cosmology.”⁷⁹ Both the Hartle-Hawking and the Vilenkin models eliminate the initial singularity by transforming the conical geometry of classical spacetime into a smooth, curved geometry having no edge (Fig. 3.7). This is accomplished by the introduction of imaginary numbers for the time variable in Einstein’s gravitational equations, which effectively eliminates the singularity.

By positing a finite (imaginary) time on a closed surface prior to the Planck time rather than an infinite time on an open surface, such models actually seem to support, rather than undercut, the fact that time and the universe had a beginning. Such theories, if successful, would enable us to model the beginning of the universe without an initial singularity involving infinite density, temperature,

74. Andrei Linde, Dmitri Linde, and Arthur Mezhlumian, “From the Big Bang Theory to the Theory of a Stationary Universe,” *Physical Review D* 49 (1994): 1783–1826. Linde has since tried to suggest a way to escape the conclusion of a beginning (“Inflation and String Cosmology,” <http://arXiv:hep-th/0503195v1> (March 24, 2005), 13. But he does not succeed in extending past spacetime paths to infinity, which is a necessary condition of the universe’s having no beginning.

75. Arvind Borde, Alan Guth, and Alexander Vilenkin, “Inflation Is Not Past-Eternal,” <http://arXiv:gr-qc/0110012v1> (Oct. 1, 2001): 4. The article was updated in January 2003.

76. Alexander Vilenkin, “Quantum Cosmology and Eternal Inflation,” <http://arXiv:gr-qc/0204061v1> (April 18, 2002): 10.

77. Borde and Vilenkin, “Eternal Inflation,” 3307.

78. Vilenkin, “Quantum Cosmology and Eternal Inflation,” 11.

79. A. Vilenkin, “Birth of Inflationary Universes,” *Physical Review D* 27 (1983): 2854. See J. Hartle and S. Hawking, “Wave Function of the Universe,” *Physical Review D* 28 (1983): 2960–75; A. Vilenkin, “Creation of the Universe from Nothing,” *Physical Letters* 117B (1982): 25–8.

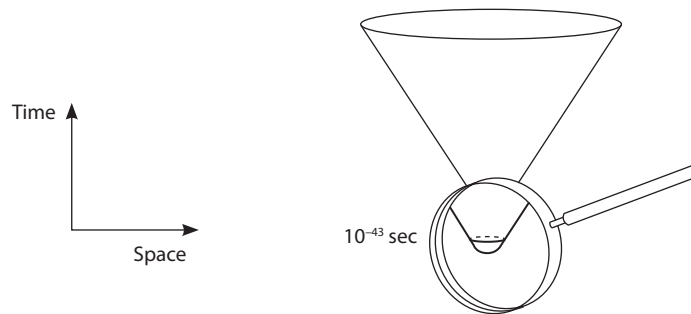

Fig. 3.7: Quantum Gravity Model. In the Hartle-Hawking version, spacetime is “rounded off” prior to the Planck time, so that although the past is finite, there is no edge or beginning point.

pressure, and so on. As Barrow points out, “This type of quantum universe has not always existed; it comes into being just as the classical cosmologies could, but it does not start at a Big Bang where physical quantities are infinite.”⁸⁰ Barrow points out that such models are “often described as giving a picture of ‘creation out of nothing,’” the only caveat being that in this case “there is no definite . . . point of creation.”⁸¹ Having a beginning does not entail having a beginning point. Even in the Standard Model, theorists sometimes “cut out” the initial singular point without thinking that therefore spacetime no longer begins to exist and the problem of the origin of the universe is thereby resolved. Time begins to exist just in case for any finite temporal interval, there are only a finite number of equal temporal intervals earlier than it. That condition is fulfilled for Quantum Gravity Models as well as for the Standard Model. According to Vilenkin, “The picture presented by quantum cosmology is that the universe starts as a small, closed 3-geometry and immediately enters the regime of eternal inflation, with new thermalized regions being constantly formed. In this picture, the universe has a beginning but no end.”⁸² Thus, Quantum Gravity models, like the Standard Model, imply the beginning of the universe.

Perhaps it will be said that such an interpretation of Quantum Gravity models fails to take seriously the notion of “imaginary time.” Introducing imaginary numbers for the time variable in Einstein’s equation has the peculiar effect of making the time dimension indistinguishable from space. But in that case, the imaginary time regime prior to the Planck time is not a spacetime at all, but a Euclidean four-dimensional space. Construed realistically, such a four-space would be evacuated of all temporal becoming and would simply exist timelessly. Hawking describes it as “completely self-contained and not affected by anything outside itself. It would be neither created nor destroyed. It would just BE.”⁸³

80. John D. Barrow, *Theories of Everything* (Oxford: Clarendon, 1991), 68.

81. *Ibid.*, 67–68.

82. Alexander Vilenkin, “Quantum Cosmology and Eternal Inflation,” 11.

83. Stephen Hawking, *A Brief History of Time* (New York: Bantam, 1988), 136.

The question which arises for this construal of the model is whether such an imaginary time regime should be interpreted realistically or instrumentally. On this score, there can be little doubt that the use of imaginary quantities for time is a mere mathematical device without ontological significance. For, first, there is no intelligible physical interpretation of imaginary time on offer. What, for example, would it mean to speak of the lapse of an imaginary second or of a physical object's enduring through two imaginary minutes? Second, time is metaphysically distinct from space, its moments being ordered by an *earlier than* relation which does not similarly order points in space. But this essential difference is obscured by imaginary time. Thus, "imaginary time" is most plausibly construed as a mathematical contrivance. Barrow observes,

physicists have often carried out this "change time into space" procedure as a useful trick for doing certain problems in ordinary quantum mechanics, although they did not imagine that time was *really* like space. At the end of the calculation, they just swop back into the usual interpretation of there being one dimension of time and three . . . dimensions of . . . space.⁸⁴

Hawking simply declines to reconvert to real numbers. If we do, then the singularity reappears. Hawking admits, "Only if we could picture the universe in terms of imaginary time would there be no singularities. . . . When one goes back to the real time in which we live, however, there will still appear to be singularities."⁸⁵ Hawking's model is thus a way of redescribing a universe with a singular beginning point in such a way that that singularity is transformed away; but such a redescription is not realist in character.

Vilenkin recognizes the use of imaginary time as a mere "computational convenience" without ontological significance.⁸⁶ Remarkably, so does Hawking in other contexts.⁸⁷ This precludes their models' being construed realistically as accounts of the origin of the spacetime universe in a timelessly existing four-space. Rather their theories are ways of modeling the real beginning of the universe *ex nihilo* in such a way as to not involve a singularity. What brought the universe into being remains unexplained on such accounts.

String Scenarios

We come finally to the extreme edge of cosmological speculation: string cosmology. These scenarios are based on an alternative to the standard quark model of

84. Barrow, *Theories of Everything*, 66–67.

85. Hawking, *Brief History of Time*, 138–39.

86. Vilenkin, *Many Worlds in One*, 182.

87. The clearest example of Hawking's instrumentalism is his description in *The Nature of Space and Time* of particle pair creation in terms of an electron's quantum tunneling in Euclidean space (with time being imaginary) and an electron/positron pair's accelerating away from each other in Minkowski spacetime. This description is directly analogous to the Hartle-Hawking cosmological model; and yet no one would construe particle pair creation as literally the result of an electron's transitioning out of a timelessly existing four-space into our classical spacetime.

elementary particle physics. So-called string theory (or M-theory) conceives of the fundamental building blocks of matter to be, not particles like quarks, but tiny, vibrating, one-dimensional strings of energy. String theory is so complicated and embryonic in its development that all its equations have not yet even been stated, much less solved. But that has not deterred some cosmologists from trying to envision cosmological scenarios based on concepts of string theory to try to avert the beginning predicted by customary Big Bang cosmology.

Two sorts of scenarios have been proposed. The first of these is the Pre-Big Bang Scenario championed by the Italian physicists Gabriele Veneziano and Maurizio Gasperini.⁸⁸ They conceive of the Big Bang as the transitional event between a contraction phase chronologically prior to the Big Bang and the observed expansion phase after it. Such a rebound is postulated on the basis of limits which the size and symmetries of strings set to the increase in quantities like spacetime curvature, density, temperature, and so forth. Prior to the Big Bang a black hole formed in the eternally preexisting, static vacuum space and collapsed to the maximum allowed values of such quantities before rebounding in the current expansion observed today (Fig. 3.8).

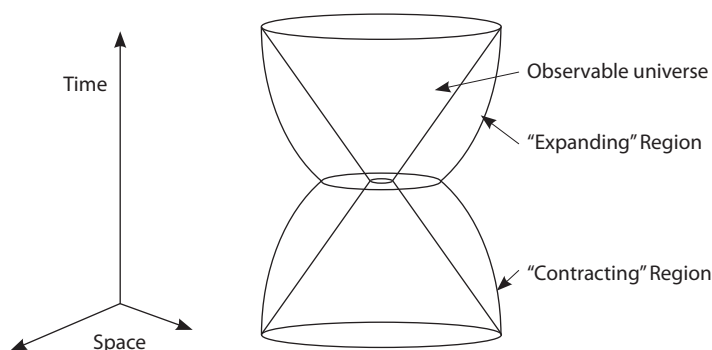

Fig. 3.8: Pre-Big Bang Scenario. Our observable universe results from the rebound of the collapse of a black hole in a wider preexisting vacuum space.

The scenario differs from the old oscillating models in that the prior contraction is conceived to take place within a wider, static space and to proceed from infinity. If the expansion will go on forever, then the contraction has gone on forever. The further one regresses into the infinite past, the less dense the universe becomes, as one approaches a limit in the infinite past of a nearly empty universe consisting of an ultra-thin gas of radiation and matter. As one moves forward in time, the material contents of various regions of space begin to collapse into black holes. But rather than collapsing to singularities, these black holes reach a maximum of

88. Gabriele Veneziano, "A Simple/Short Introduction to Pre-Big Bang Physics/Cosmology," <http://arXiv:hep-th/9802057v2> (March 2, 1998); M. Gasperini, "Looking Back in Time beyond the Big Bang," *Modern Physics Letters A* 14/16 (1999): 1059–66; M. Gasperini, "Inflation and Initial Conditions in the Pre-Big Bang Scenario," *Physics Review D* 61 (2000): 87301–305; M. Gasperini and G. Veneziano, "The Pre-Big Bang Scenario in String Cosmology," <http://arXiv:hep-th/0207130v1> (July 12, 2002).

spacetime curvature, density, and so on, before rebounding into expansion phases. Our universe is just one of these collapsing and rebounding regions within the wider universe. Thus, an absolute beginning of the universe is averted.

Although the Pre-Big Bang Scenario is based on a non-existent theory and is dogged with problems concerning how to join the pre- and post-Big Bang phases together, these purely physical problems pale in comparison to the deep conceptual difficulties attending such a scenario. Like the old Vacuum Fluctuation Models, the Pre-Big Bang Scenario postulates an eternal, static space in which our observable universe originates via a Big Bang event a finite time ago. But since there is a positive probability of a black hole's forming in any patch of pre-existing space, such an event, given infinite past time, would have happened infinitely long ago, which is inconsistent with the finite age of our observable universe. Moreover, all the pre-Big Bang black holes should in infinite time have coalesced into one massive black hole coextensive with the universe, so that the post-Big Bang universe ought to be observed as infinitely old. Similarly, such a static wider universe, if it is a closed system, should, given infinite past time, have already arrived at a state of thermodynamic equilibrium, in contradiction to the observed disequilibrium (more on this in the sequel). In their efforts to explain the origin of the observable universe from a pre-Big Bang condition, Gasperini and Veneziano have been singularly inattentive to the problematic issues arising from their supposition of a wider, eternally pre-existing space. What they have done, in effect, is to treat the past as a potentially infinite process approaching an infinitely distant limit, rather than as an actually infinite sequence of events having no beginning but an end in the present.

The more celebrated of the string scenarios has been the so-called Ekpyrotic Scenario championed by Paul Steinhardt.⁸⁹ In the most recent revision, the Cyclic Ekpyrotic Scenario, we are asked to envision two three-dimensional membranes (or "branes" for short) existing in a five-dimensional spacetime (Fig. 3.9). One of these branes is our universe. These two branes are said to be in an eternal cycle in which they approach each other, collide, and retreat again from each other. It is the collision of the other brane with ours that causes the expansion of our universe. With each collision, the expansion is renewed. Ripples in the branes are said to account for the large-scale structure of our three-dimensional universe. Thus, even though our universe is expanding, it never had a beginning.

Again, wholly apart from its speculative nature, the Ekpyrotic Scenario has been plagued with problems.⁹⁰ But let that pass. Perhaps all these problems can somehow be solved. The more important point is that it turns out that, like the Chaotic Inflationary Model, the Cyclic Ekpyrotic Scenario cannot be eternal in the past. With the formulation of their stronger theorem Borde, Guth, and

89. See <http://feynman.princeton.edu/~steinh/>.

90. For typical criticisms see especially Gary Felder, Andrei Frolov, Lev Kaufman, and Andrei Linde, "Cosmology with Negative Potentials," <http://arXiv:hep-th/0202017v2> (February 16, 2002) and the therein cited literature, particularly the studies by David Lyth.

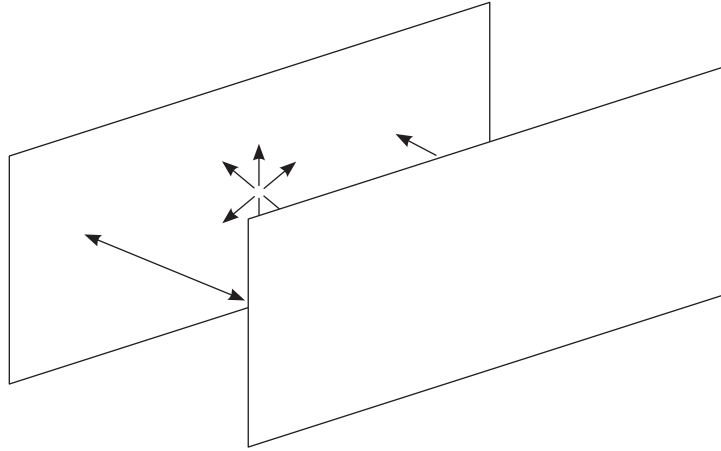

Fig. 3.9: Cyclic Ekpyrotic Scenario. Two three-dimensional membranes in an eternal cycle of approach, collision, and retreat. With each collision the expansion of our universe is re-invigorated.

Vilenkin were able to generalize their earlier results on inflationary models in such a way to extend their conclusion to other models. Indeed, the new theorem implies that any universe which has on average been globally expanding at a positive rate is geodesically incomplete in the past and therefore has a past boundary. Specifically, they note, “Our argument can be straightforwardly extended to cosmology in higher dimensions,” specifically brane-cosmology like Steinhardt’s.⁹¹ According to Vilenkin, “It follows from our theorem that the cyclic universe is past-incomplete,”⁹² that is to say, the need for an initial singularity has not been eliminated. Therefore, such a universe cannot be past-eternal. Steinhardt has himself come to recognize this implication of the theorem for Ekpyrotic Scenarios and so now acknowledges that on his scenario the universe has a past boundary at some point in the metrically finite past.⁹³

Summary

The history of twentieth-century cosmogony has, in one sense, been a series of failed attempts to craft acceptable non-standard models of the expanding universe in such a way as to avert the absolute beginning predicted by the Standard Model. This parade of failures can be confusing to the layman, leading him mistakenly to

91. Borde, Guth, and Vilenkin, “Inflation Is Not Past-Eternal,” 4. See also Alexander Vilenkin, “Quantum Cosmology and Eternal Inflation,” 11.

92. Alexander Vilenkin, personal communication.

93. See www.phy.princeton.edu/~steinh/ under “Answers to Frequently Asked Questions: Has the cyclic model been cycling forever?” Steinhardt seeks to mollify the impact of the Borde-Guth-Vilenkin theorem by maintaining that clocks run progressively faster as one approaches the past boundary, so that elapsed time becomes what he calls “semi-infinite.” This trick does nothing to abrogate the finitude of the past or the beginning of the universe.

infer that the field of cosmology is in constant flux, as new theories of the universe's origin continually come and go, with no assured results. In fact, the Standard Model's prediction of an absolute beginning has persisted through a century of astonishing progress in theoretical and observational cosmology and survived an onslaught of alternative theories. With each successive failure of alternative cosmogonic theories to avoid the absolute beginning of the universe predicted by the Standard Model, that prediction has been corroborated. It can be confidently said that no cosmogonic model has been as repeatedly verified in its predictions and as corroborated by attempts at its falsification, or as concordant with empirical discoveries and as philosophically coherent, as the Standard Big Bang Model.

A watershed of sorts appears to have been reached in 2003 with Borde, Guth, and Vilenkin's formulation of their theorem establishing that any universe which has on average over its past history been in a state of cosmic expansion cannot be eternal in the past but must have a spacetime boundary. Theorists intent on avoiding the absolute beginning of the universe could previously always take refuge in the period prior to the Planck time, an era so poorly understood that one commentator has compared it with the regions on the maps of ancient cartographers marked "Here there be dragons!"—it can be filled with all sorts of chimeras. But the Borde-Guth-Vilenkin theorem does not depend upon any particular physical description of the universe prior to the Planck time, being based instead on deceptively simple physical reasoning which will hold regardless of our uncertainty concerning that era. It single-handedly sweeps away the most important attempts to avoid the absolute beginning of the universe, especially the darling of current cosmologists, the eternal inflationary multiverse. Vilenkin pulls no punches: "It is said that an argument is what convinces reasonable men and a proof is what it takes to convince even an unreasonable man. With the proof now in place, cosmologists can no longer hide behind the possibility of a past-eternal universe. There is no escape, they have to face the problem of a cosmic beginning."⁹⁴

Of course, in view of the metaphysical issues raised by the prospect of a beginning of the universe, we may be confident that the quest to avert the absolute beginning predicted by the Standard Model will continue unabated. Such efforts are to be encouraged, and we have no reason to think that such attempts at falsification of the prediction of the Standard Model will result in anything other than further corroboration of its prediction of a beginning. While scientific evidence is always provisional, there can be little doubt in this case where the evidence points.

Scientific Arguments:

(4) The Thermodynamic Properties of the Universe

As if this were not enough, there is a second scientific confirmation for the beginning of the universe, the evidence from thermodynamics. According to the second law of thermodynamics, processes taking place in a closed system always tend

94. Vilenkin, *Many Worlds in One*, 176.

toward a state of equilibrium. In other words, unless energy is constantly being fed into a system, the processes in the system will tend to run down and quit. For example, if I had a bottle that was a sealed vacuum inside, and I introduced into it some molecules of gas, the gas would spread itself out evenly inside the bottle. It is virtually impossible for the molecules to retreat, for example, into one corner of the bottle. This is why when you walk into a room, the air in the room never separates suddenly into oxygen at one end and nitrogen at the other. It's also why when you step into your bath you may be confident that it will be an even temperature instead of frozen solid at one end and boiling at the other. It's clear that life would not be possible in a world in which the second law of thermodynamics did not hold.

Cosmological Implications of the Second Law

Now our interest in the law is what happens when it is applied to the universe as a whole. For the universe is, on the atheistic view, a gigantic closed system, since it is everything there is and there is nothing outside it. Already in the nineteenth century, scientists realized that the application of the second law to the universe as a whole implied a grim eschatological conclusion: given sufficient time, the universe will eventually come to a state of equilibrium and suffer "heat death." Once the universe reaches this state, no further change is possible. The universe is dead.

But this apparently firm projection raised an even deeper question: if, given sufficient time, the universe will suffer heat death, then why, if it has existed forever, is it not now in a state of heat death? If in a finite amount of time the universe will inevitably come to equilibrium, from which no significant further change is physically possible, then it should already be at equilibrium by now, if it has existed for infinite time. Like a ticking clock, it should by now have run down. Since it has not yet run down, this implies, in the words of Richard Schlegel, that "in some way the universe must have been *wound up*."⁹⁵

The nineteenth-century German physicist Ludwig Boltzmann offered a daring hypothesis in order to explain why we do not find the universe in a state of heat death or thermodynamic equilibrium.⁹⁶ Boltzmann hypothesized that the universe as a whole *does*, in fact, exist in an equilibrium state, but that over time fluctuations in the energy level occur here and there throughout the universe, so that by chance alone there will be isolated regions where disequilibrium exists. Boltzmann referred to these isolated regions as "worlds." We should not be surprised to see our world in a highly improbable disequilibrium state, he maintained, since in the ensemble of all worlds there must exist by chance certain worlds in disequilibrium, and ours just happens to be one of these.

95. Richard Schlegel, "Time and Thermodynamics," in *The Voices of Time*, ed. J. T. Fraser (London: Penguin, 1968), 511.

96. Ludwig Boltzmann, *Lectures on Gas Theory*, trans. Stephen G. Brush (Berkeley: University of California Press, 1964), §90, pp. 446–48.

The problem with Boltzmann's hypothesis was that if our world were merely a fluctuation in a sea of diffuse energy, then it is overwhelmingly more probable that we should be observing a much tinier region of disequilibrium than we do. In order for us to exist, a smaller fluctuation would have sufficed and is much more probable than one so large as the observable universe. Moreover, even a colossal fluctuation that produced our world instantaneously by an enormous accident is inestimably more probable than a progressive decline in entropy over billions of years to fashion the world we see. In fact, Boltzmann's hypothesis, if adopted, would force us to regard the past as illusory, everything having the mere appearance of age, and the stars and planets as illusory, mere "pictures" as it were, since that sort of world is vastly more probable given a state of overall equilibrium than a world with genuine, temporally and spatially distant events. Therefore, Boltzmann's hypothesis has been universally rejected by the scientific community, and the present disequilibrium is usually taken to be just a result of the initial low entropy condition mysteriously obtaining at the beginning of the universe.

Eschatological Scenarios

The advent of relativity theory and its application to cosmology altered the shape of the eschatological scenario predicted on the basis of the second law of thermodynamics but did not materially affect the fundamental question. Assuming that there is no positive cosmological constant fueling the expansion of the universe, that expansion will decelerate over time. Two radically different eschatological scenarios then present themselves. If the density of the universe exceeds a certain critical value, then the internal pull of the universe's own gravity will eventually overcome the force of the expansion and the universe will collapse in upon itself in a fiery Big Crunch. Beatrice Tinsley described such a scenario:

If the average density of matter in the universe is great enough, the mutual gravitational attraction between bodies will eventually slow the expansion to a halt. The universe will then contract and collapse into a hot fireball. There is no known physical mechanism that could reverse a catastrophic big crunch. Apparently, if the universe becomes dense enough, it is in for a hot death.⁹⁷

If the universe is fated to re-contraction, then as it contracts the stars gain energy, causing them to burn more rapidly so that they finally explode or evaporate. As everything in the universe grows closer together, the black holes begin to gobble up everything around them and eventually begin themselves to coalesce. In time, "all the black holes finally coalesce into one large black hole that is coextensive with the universe," from which the universe will never reemerge.⁹⁸ There is no known physics that would permit the universe to bounce back to a new expansion prior to a final singularity or to pass through the singularity into a subsequent state.

97. Beatrice Tinsley, "From Big Bang to Eternity?" *Natural History Magazine* (October 1975), 103.

98. Duane Dicus, et al., "The Future of the Universe," *Scientific American*, March 1983, 99.

On the other hand, if the density of the universe is equal to or less than the critical value, then gravity will not overcome the force of the expansion and the universe will expand forever at a progressively slower rate. Tinsley described the fate of this universe:

If the universe has a low density, its death will be cold. It will expand forever at a slower and slower rate. Galaxies will turn all of their gas into stars, and the stars will burn out. Our own sun will become a cold, dead remnant, floating among the corpses of other stars in an increasingly isolated Milky Way.⁹⁹

At 10^{30} years the universe will consist of 90 percent dead stars, 9 percent supermassive black holes formed by the collapse of galaxies, and 1 percent atomic matter, mainly hydrogen. Elementary particle physics suggests that thereafter protons will decay into electrons and positrons, so that space will be filled with a rarefied gas so thin that the distance between an electron and a positron will be about the size of the present galaxy. At 10^{100} years, the commencement of the so-called Dark Era, some scientists believe that the black holes themselves will dissipate by a strange effect predicted by quantum mechanics. The mass and energy associated with a black hole so warp space that they are said to create a “tunnel” or “worm-hole” through which the mass and energy are ejected in another region of space. As the mass of a black hole decreases, its energy loss accelerates, so that it is eventually dissipated into radiation and elementary particles. Eventually all black holes will completely evaporate and all the matter in the ever-expanding universe will be reduced to a thin gas of elementary particles and radiation. Because the volume of space constantly increases, the universe will never actually arrive at equilibrium, since there is always more room for entropy production. Nonetheless, the universe will become increasingly cold, dark, dilute, and dead.

Very recent discoveries provide strong evidence that there is effectively a positive cosmological constant which causes the cosmic expansion to accelerate rather than decelerate. Paradoxically, since the volume of space increases exponentially, allowing greater room for further entropy production, the universe actually grows farther and farther from an equilibrium state as time proceeds. But the acceleration only hastens the cosmos’s disintegration into increasingly isolated material patches no longer causally connected with similarly marooned remnants of the expanding universe. Each of these patches faces, in turn, thermodynamic extinction. Therefore, the grim future predicted on the basis of the second law remains fundamentally unaltered.

Thus, the same pointed question raised by classical physics persists: why, if the universe has existed forever, is it not now in a cold, dark, dilute, and lifeless state? In contrast to their nineteenth-century forbears, contemporary physicists have come to question the implicit assumption that the universe is past eternal. Davies reports,

99. Tinsley, “Big Bang,” 105.

Today, few cosmologists doubt that the universe, at least as we know it, did have an origin at a finite moment in the past. The alternative—that the universe has always existed in one form or another—runs into a rather basic paradox. The sun and stars cannot keep burning forever: sooner or later they will run out of fuel and die.

The same is true of all irreversible physical processes; the stock of energy available in the universe to drive them is finite, and cannot last for eternity. This is an example of the so-called second law of thermodynamics, which, applied to the entire cosmos, predicts that it is stuck on a one-way slide of degeneration and decay towards a final state of maximum entropy, or disorder. As this final state has not yet been reached, it follows that the universe cannot have existed for an infinite time.¹⁰⁰

Davies concludes, “The universe can’t have existed forever. We know there must have been an absolute beginning a finite time ago.”¹⁰¹

Oscillating Models

During the 1960s and 1970s some scientists tried to escape this conclusion by arguing that the universe oscillates in and out from eternity, and so never reaches a final state of equilibrium (Fig. 3.4). But wholly apart from the difficulties mentioned earlier, the fact is that the thermodynamic properties of oscillating models imply the very beginning of the universe that their proponents sought to avoid. For entropy is conserved from cycle to cycle in such models, which has the effect of generating larger and longer oscillations with each successive cycle (Fig. 3.10).

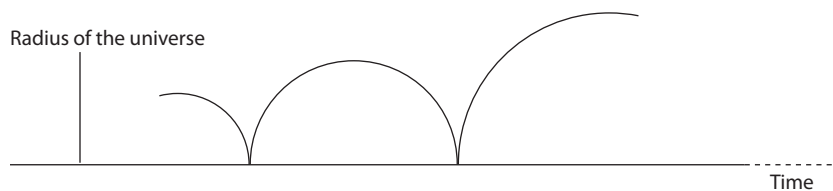

Fig. 3.10: Oscillating Model with entropy increase. Due to the conservation of entropy each successive oscillation has a larger radius and longer expansion time.

Therefore, if one traced the expansions back in time they would get smaller and smaller and smaller. One scientific team explains, “The effect of entropy production will be to enlarge the cosmic scale, from cycle to cycle. . . . Thus, looking back in time, each cycle generated less entropy, had a smaller cycle time, and had a smaller cycle expansion factor than [*sic*] the cycle that followed it.”¹⁰² Therefore, in the words of another scientific team, “the multicycle model has an infinite future, but

100. Paul Davies, “The Big Bang—and Before,” The Thomas Aquinas College Lecture Series, Thomas Aquinas College, Santa Paula, Calif., March 2002.

101. Paul Davies, “The Big Questions: In the Beginning,” ABC Science Online, interview with Phillip Adams, <http://aca.mq.edu.au/pdavieshtml>.

102. Dicus, “Cosmological Future,” 1, 8.

only a finite past.”¹⁰³ Indeed, astronomer Joseph Silk estimates on the basis of the current level of entropy in the universe that it could not have gone through more than 100 previous oscillations.¹⁰⁴

Even if this difficulty were avoided, a universe oscillating from eternity past would require an infinitely precise tuning of initial conditions in order to persist through an infinite number of successive bounces. A universe rebounding from a single, infinitely long contraction is, if entropy increases during the contracting phase, incompatible with the initial low entropy condition of our expanding phase. Postulating an entropy decrease during the contracting phase in order to escape this problem would violate the second law. In either case such a universe involves a radical fine-tuning of a very special sort, since the initial conditions have to be set at $-\infty$ in the past.¹⁰⁵

Baby Universes

Is there some other plausible way of holding onto the eternity of the past in the face of the universe’s disequilibrium state? Speculations have been floated in eschatological discussions about our universe’s begetting future “baby universes.” It has been conjectured that black holes may be portals of wormholes through which bubbles of false vacuum energy can tunnel to spawn new expanding baby universes, whose umbilical cords to our universe may eventually snap as the wormholes close up, leaving the baby universe an independently existing spacetime (Fig. 3.11). Perhaps we might imagine that our observable universe is just one of the newly birthed offspring of an infinitely old, preexisting universe.

The conjecture of our universe’s spawning future offspring by such a mechanism was the subject of a bet between Stephen Hawking and James Preskill, which Hawking in 2004 finally admitted, in an event much publicized in the press, that he had lost.¹⁰⁶ The conjecture would require that information locked up in a black hole could be utterly lost forever by escaping to another universe. One of the last holdouts, Hawking finally came to agree that quantum theory requires that information is preserved in black hole formation and evaporation. The implica-

103. I.D. Novikov and Ya. B. Zeldovich, “Physical Processes Near Cosmological Singularities,” *Annual Review of Astronomy and Astrophysics* 11 (1973): 401–2.

104. Joseph Silk, *The Big Bang*, 2nd ed. (San Francisco: W. H. Freeman, 1989), 311–12.

105. Cosmologist George Ellis remarks: “The problems are related: first, initial conditions have to be set in an extremely special way at the start of the collapse phase in order that it is a Robertson-Walker universe collapsing; and these conditions have to be set in an acausal way (in the infinite past). It is possible, but a great deal of inexplicable fine tuning is taking place: how does the matter in widely separated causally disconnected places at the start of the universe know how to correlate its motions (and densities) so that they will come together correctly in a spatially homogeneous way in the future? Secondly, if one gets that right, the collapse phase is unstable, with perturbations increasing rapidly, so only a very fine-tuned collapse phase remains close to Robertson-Walker even if it started off so, and will be able to turn around as a whole (in general many black holes will form locally and collapse to a singularity). G. F. R. Ellis to James Sinclair, January 25, 2006.

Ellis then pointedly asks, “Who focused the collapse so well that it turns around nicely?”

106. For a firsthand account see James Preskill’s website www.theory.caltech.edu/~preskill/jp-24jul04.html.

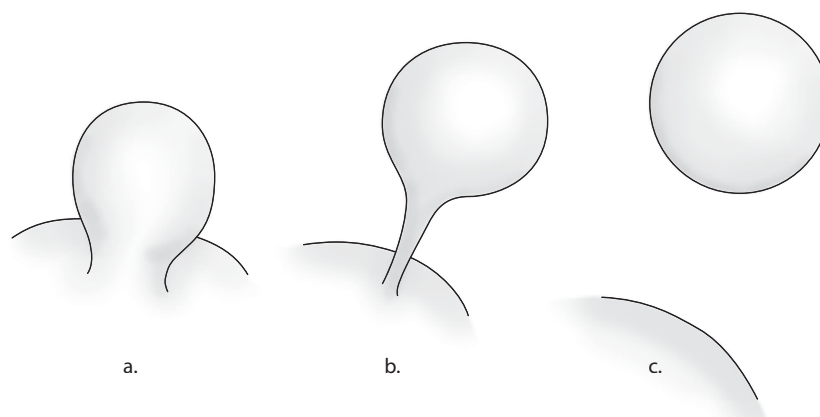

Fig. 3.11. Birth of a baby universe. A baby universe spawned from its mother universe eventually becomes a disconnected and causally isolated spacetime.

tions? “There is no baby universe branching off, as I once thought. The information remains firmly in our universe. I’m sorry to disappoint science fiction fans, but if information is preserved, there is no possibility of using black holes to travel to other universes.”¹⁰⁷ Even if Hawking had won the bet, could such an eschatological scenario be in any case successfully extrapolated into the past, such that our universe is one of the baby universes spawned by the mother universe or by an infinite series of ancestors? It seems not, for while such baby universes appear as black holes to observers in the mother universe, an observer in the baby universe itself will see the Big Bang as a white hole spewing out energy. But this is in sharp contrast to our observation of the Big Bang as a low-entropy event with a highly constrained geometrical structure.

Inflationary Multiverse

Inflationary theory has been exploited by some theorists in an attempt to revive Boltzmann’s explanation of why we find ourselves in a universe thermodynamically capable of sustaining observers. The question here, in the words of Dyson, Kleban, and Susskind, is “whether the universe can be a naturally occurring fluctuation, or must it be due to an external agent which starts the system out in a specific low entropy state?”¹⁰⁸ According to generic inflationary theory, our universe exists in a

107. S. W. Hawking, “Information Loss in Black Holes,” <http://arXiv:hep-th/0507171v2> (15 September 2005): 4.

108. Lin Dyson, Matthew Kleban, and Leonard Susskind, “Disturbing Implications of a Cosmological Constant,” <http://arXiv.org/abs/hep-th/0208013v3> (November 14, 2002), 4. Their point of departure is Henri Poincaré’s argument that in a closed box of randomly moving particles every configuration of particles, no matter how improbable, will eventually recur, given enough time; given infinite time, every configuration will recur infinitely many times. Eschewing a global perspective in favor of a restriction to our causally connected patch of the universe, they argue for the inevitability of cosmological Poincaré recurrences, allowing the process of cosmogony to begin anew. N.B. that even if bubble universes decay before the Poincaré recurrences could happen, there is still enough time for the invasion of Boltzmann brains, discussed below.

true vacuum state with an energy density that is nearly zero; but earlier it existed in a false vacuum state with a very high energy density. If we hypothesize that the conditions determining the energy density and evolution of the false vacuum state were just right, then the false vacuum will expand so rapidly that, as it decays into bubbles of true vacuum, the “bubble universes” formed in this sea of false vacuum, though themselves expanding at enormous rates, will not be able to keep up with the expansion of the false vacuum and so will find themselves increasingly separated with time (Fig. 3.12).

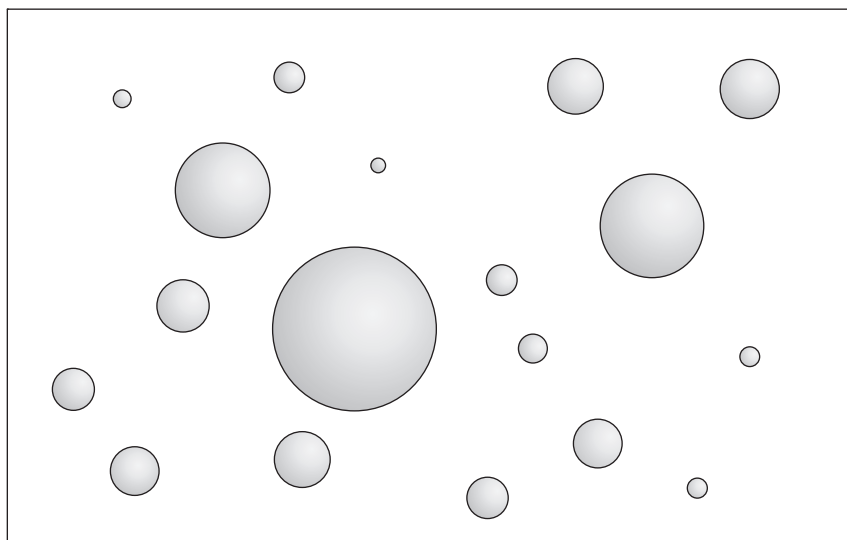

Fig. 3.12. Bubbles of true vacuum in a sea of false vacuum. As the inflating false vacuum decays, bubbles of true vacuum form in the false vacuum, each constituting an expanding universe. Though rapidly expanding, the bubbles will not coalesce because the false vacuum continues to expand at an even more rapid rate.

Moreover, each bubble is subdivided into domains bounded by event horizons, each domain constituting an observable universe. Observers internal to such a universe will observe it to be open and infinite, even though externally the bubble universe is finite and geometrically closed. Despite the fact that the multiverse is itself finite and geometrically closed, the false vacuum will, according to the theory, go on expanding forever. New bubbles of true vacuum will continue to form in the gaps between the bubble universes and become themselves isolated worlds.

The proposed solution to the problem, then, is essentially the same as Boltzmann's. Among the infinity of worlds generated by inflation there will be some worlds that are in a state of thermodynamic disequilibrium, and only such worlds can support observers. It is therefore not surprising that we find the world in a state of disequilibrium, since that is the only kind of world that we could observe.

But then the proposed solution is plagued by the same failing as Boltzmann's hypothesis. In a multiverse of eternally inflating vacua most of the volume will be occupied by high entropy, disordered states incapable of supporting observers. There are two ways in which observable states can exist: first, by being part of a relatively young, low entropy world, or, second, by being a thermal fluctuation in a high entropy world. Even though young universes are constantly nucleating out of the false vacuum, their volumes will be small in comparison with the older bubbles. Disordered states will therefore be on average strongly predominant. That implies that observers are much more likely to be the result of thermal fluctuations than the result of young, low entropy conditions.

But then the objection once again arises that it is incomprehensibly more probable that a much smaller region of disequilibrium should arise via a fluctuation than a region as large as our observable universe. Roger Penrose calculates that the odds of our universe's initial low entropy condition's coming into existence are on the order of one part in $10^{10(123)}$.¹⁰⁹ He comments, "I cannot even recall seeing anything else in physics whose accuracy is known to approach, even remotely, a figure like one part in $10^{10(123)}$."¹¹⁰ By contrast, the odds of our solar system's being formed instantly by random collisions of particles is about $1:10^{10(60)}$, a vast number, but inconceivably smaller than $10^{10(123)}$. (Penrose calls it "utter chicken feed" by comparison.¹¹¹) Thus, in the multiverse of worlds, observable states involving such an initial low entropy condition will be an incomprehensibly tiny fraction of all the observable states there are. If we are just one random member of an ensemble of worlds, we should therefore be observing a smaller world.

Adopting the multiverse hypothesis to explain our ordered observations would thus result once more in a strange sort of illusionism. It would be overwhelmingly more probable that there really isn't a vast, orderly universe out there, despite our observations; it's all an illusion. Indeed, the most probable state which is adequate to support our ordered observations is an even smaller "universe" consisting of a single brain which appears out of the disorder via a thermal fluctuation. In all probability, then, you alone exist, and everything you observe around you, even your physical body, is illusory! Some cosmologists have, in melodramatic language reminiscent of grade-B horror movies of the 1950s, dubbed this problem "the invasion of the Boltzmann brains."¹¹² Boltzmann brains are much more plenteous in the ensemble of universes than ordinary observers, and, therefore, each of us ought to think that he is himself a Boltzmann brain if he believes that the universe is but

109. Roger Penrose, "Time-Asymmetry and Quantum Gravity," in *Quantum Gravity 2*, ed. C.J. Isham, R. Penrose, and D. W. Sciama (Oxford: Clarendon, 1981), 249; cf. Hawking and Penrose, *Nature of Space and Time*, 34–5.

110. Penrose, "Time-Asymmetry," 249.

111. Roger Penrose, *The Road to Reality* (New York: Alfred A. Knopf, 2005), 762–65.

112. For literature see Don N. Page, "Return of the Boltzmann Brains," (November 15, 2006), <http://arXiv:hep-th/0611158>. See especially Andrei Linde, "Sinks in the Landscape, Boltzmann Brains, and the Cosmological Constant Problem," <http://arXiv:hep-th/0611043> and the articles by Dyson, et al., by Bousoff and Freivogel, and by Banks cited below.

one member of an ensemble of worlds. Since that seems crazy, that fact strongly disconfirms the hypothesis that there is a multiverse old enough and big enough to have evolved sufficient volume to account for our low entropy condition's appearing by chance.

One might try to avoid the problem by holding that no bubble universe eternally inflates, so that what one theorist calls “respectable, ordinary observers like us” dominate on average. But as Bousso and Freivogel protest, “Such a conclusion would be shocking and is at odds with our current, admittedly crude, understanding of the string landscape.”¹¹³ They therefore advise that we avoid the problem by shunning the “global point of view” in favor of a purely local picture of our “causal diamond,” that is, the spacetime patch which an observer can causally influence and be influenced by. “In the local picture, the causal diamond is all there is. No-one can go and probe the exponentially large regions allegedly created by the cosmological expansion, so we do not consider them to be part of reality.”¹¹⁴ Taken as serious metaphysics, one can only regard this proposal as an outrageous example of Verificationism at work. Our inability to probe areas outside our causal diamond gives absolutely no warrant for thinking that these regions are unreal and therefore cosmically irrelevant.¹¹⁵ Moreover, regarding the wider universe as literally unreal would be to give up the multiverse hypothesis, so that we are right back where we started in trying to explain our observed disequilibrium!

By contrast, if we postulate the finitude of past time and space, such problems are avoided.¹¹⁶ The reason for the observed disequilibrium state is that spacetime

113. R. Bousso and B. Freivogel, “A paradox in the global description of the multiverse,” <http://arXiv:hep-th/0610132>, 6.

114. *Ibid.*, 7.

115. Even on the local point of view we still face the problem of the Poincaré recurrences (n. 108). Dyson, Kleban, and Susskind recognize that the fatal weakness of the hypothesis that our observable universe is the result of such a chance recurrence is that there are “far more probable ways of creating livable (anthropically acceptable) environments” than those that begin in a low entropy condition. Susskind thinks that the recurrence problems can be avoided because the bubble universes decay into terminal states in which life can never again arise before the recurrences have time to take place. But Banks points out that the problem of the Boltzmann Brains remains unresolved: “The real prediction is that the dominant form of intelligent life in the DKS universe is a form created spontaneously with knowledge of a spurious history, which lives just long enough to realize that its memories are faulty. . . . The DKS model . . . appears to founder on the bizarre phenomenon of Boltzmann’s brain” (T. Banks, “Entropy and Initial Conditions in Cosmology,” <http://arXiv-hep-th/0701146> v1 [January 1, 2007], 16, 31).

116. Dyson, Kleban, and Susskind respond to such a suggestion as follows: “Another possibility is that an unknown agent intervened in the evolution and for reasons of its own restarted the universe in the state of low entropy characterizing inflation. However, even this does not rid the theory of the pesky recurrences. Only the first occurrence would evolve in a way that would be consistent with usual expectations” (Dyson, Kleban, and Susskind, “Disturbing Implications of a Cosmological Constant,” 20–21). But so saying, they have misconstrued the hypothesis. The hypothesis was not of an external agent which “restarted” the universe but of “an external agent which *starts the system out* in a specific low entropy state” (*ibid.*, 4). On such a hypothesis “some unknown agent initially started the inflation high up on its potential, and the rest is history” (*Ibid.*, 2). On this hypothesis the recurrence problems do even not arise. By contrast, Dyson, Kleban, and Susskind are finally driven to suggest that “perhaps the only reasonable conclusion is that we

had an absolute beginning in a low entropy condition a finite time ago and is on its way toward states of increasing disorder.

In any case it is now widely acknowledged that a future-eternal inflationary universe, which constitutes the *sine qua non* for the multiverse proposal, cannot be past-eternal. Linde, you'll recall, once proposed that a model of the universe which is eternally inflating toward the future might also be extended infinitely into the past, but the Borde-Guth-Vilenkin Theorem closed the door on that possibility. The attempt to revive the Boltzmann hypothesis thus relies upon a mechanism which itself requires the finitude of the past and so a beginning of time and space.

Summary

Thermodynamics implies that the universe had a beginning. In a certain respect, the evidence of thermodynamics is even more impressive than the evidence afforded by the expansion of the universe. For while an accurate physical description of the universe prior to the Planck time remains and perhaps always will remain unknown, thereby affording room for speculations aimed at averting the origin of time and space implied by the expanding cosmos, no such uncertainty attends the laws of thermodynamics and their application. Indeed, thermodynamics is so well established that this field is virtually a closed science.¹¹⁷ Even though we may not like it, concludes Davies, we must say on the basis of the thermodynamic properties of the universe that the universe's energy was somehow simply "put in" at the creation as an initial condition.¹¹⁸ Prior to the creation, says Davies, the universe simply did not exist.¹¹⁹

THE UNIVERSE HAS A CAUSE

On the basis of the four arguments for the finitude of the past, we have good grounds for affirming the second premise of the *kalām* cosmological argument, that *the universe began to exist*. From the first premise—that *whatever begins to exist has a cause*—and the second premise, it follows logically that *the universe has a cause*. This conclusion ought to stagger us, to fill us with awe, for it means that the universe was brought into existence by *something* which is greater than and beyond it.

do not live in a world with a true cosmological constant" (ibid., 21), a desperate hypothesis which flies in the face of the evidence and fails in any case to address the global problem.

117. One recalls Eddington's remark: "The second law of thermodynamics holds, I think, the supreme position among the laws of Nature. If someone points out to you that your pet theory of the universe is in disagreement with Maxwell's equations—then so much the worse for Maxwell's equations. If it is found to be contradicted by observation, well, these experimentalists do bungle things sometimes. But if your theory is found to be against the second law of thermodynamics I can give you no hope; there is nothing for it but collapse in deepest humiliation." Arthur S. Eddington, *The Nature of the Physical World* (New York: Macmillan), 74.

118. P. C. W. Davies, *The Physics of Time Asymmetry* (London: Surrey University Press, 1974), 104.

119. My thanks to James Sinclair for his comments on the section concerning scientific arguments for the universe's beginning.

Or does it? Dennett, as we have seen, agrees that the universe must have a cause of its beginning. But, he claims, the cause of the universe is itself; the universe brought itself into being! Dennett writes:

What does need its origin explained is the concrete Universe itself, and as Hume . . . long ago asked: Why not stop at the material world? It . . . does perform a version of the ultimate bootstrapping trick; it creates itself *ex nihilo*. Or at any rate out of something that is well-nigh indistinguishable from nothing at all.¹²⁰

Here Dennett spoils his radical idea by waffling at the end: maybe the universe did not create itself out of nothing but at least out of something well-nigh indistinguishable from nothing. This caveat evinces a lack of appreciation of the metaphysical chasm between being and nothingness. There is no third thing between being and non-being; if anything at all exists, however ethereal, it is something and therefore not nothing. So what could this mysterious something be? Dennett does not tell us. In fact, he seems somewhat impatient with the question. He complains:

This leads in various arcane directions, into the strange precincts of string theory and probability fluctuations and the like, at one extreme, and into ingenious nitpicking about the meaning of “cause” at the other. Unless you have a taste for mathematics and theoretical physics on the one hand, or the niceties of scholastic logic on the other, you are not apt to find any of this compelling, or even fathomable.¹²¹

How strange that Dennett, who fancies himself, unlike Christian dullards, to be among the “brights,” should indict an argument because it appeals only to the inquisitive and the intelligent! In any case, the appeal of the argument is irrelevant; if even Dennett’s complaint were correct, it constitutes at best a piece of friendly, atheistic advice to believers about the limited utility of the *kalām* cosmological argument in evangelism. We can thank Professor Dennett for his advice, while still demanding an account of the origin of the universe.

The best sense I can make of Dennett’s suggestion is to construe it as an endorsement of a model of quantum creation such as is offered by his Tufts University colleague Alexander Vilenkin. It will be recalled that Vilenkin equates the initial state of the universe explanatorily prior to quantum tunneling with nothingness. Unfortunately, we saw that this equivalence is clearly mistaken (perhaps Dennett’s waffling betrays an understanding of this fact). Thus, on Vilenkin’s model we are still left wondering what caused the initial state of the universe to come into being.

Dennett’s answer is: the universe, in the ultimate boot-strapping trick, created itself! Dennett’s bold hypothesis would at least help to resolve the objection that if something can come into being out of nothing, then it becomes inexplicable why anything and everything does not come into being out of nothing. On Dennett’s

120. Dennett, *Breaking the Spell*, 244.

121. *Ibid.*, 242.

view the coming of the universe into being is causally constrained: it creates itself. Of course, that still leaves us wondering why other things, say, bicycles and hot dogs and wombats, do not have the same capacity; but never mind. As Aquinas argued, self-creation is metaphysically absurd, since in order to cause itself to come into being, the universe would have to already exist. One is thus caught in a vicious circle. Aquinas made the point with respect to an eternally existing universe, but his argument is even more forceful with respect to a universe with a beginning. For in the latter case the universe must be not only explanatorily prior to itself but even, it seems, chronologically prior to itself, which is incoherent. Thus, Dennett's imaginative suggestion is wholly untenable.

The Nature of the First Cause

It therefore follows that the universe has an external cause. Conceptual analysis enables us to recover a number of striking properties which must be possessed by such an ultra-mundane being. For as the cause of space and time, this entity must transcend space and time and therefore exist atemporally and non-spatially (at least without the universe).¹²² This transcendent cause must therefore be changeless and immaterial, since timelessness entails changelessness, and changelessness implies immateriality. Such a cause must be beginningless and uncaused, at least in the sense of lacking any antecedent causal conditions, since there cannot be an infinite regress of causes. Ockham's Razor (the principle which states that we should not multiply causes beyond necessity) will shave away further causes. This entity must be unimaginably powerful, since it created the universe without any material cause.

Finally, and most remarkably, such a transcendent cause is plausibly to be taken to be personal. Three reasons can be given for this conclusion. First, as Richard Swinburne points out, there are two types of causal explanation: scientific explanations in terms of laws and initial conditions and personal explanations in terms of agents and their volitions.¹²³ For example, if I come into the kitchen and find the kettle boiling, and I ask Jan, "Why is the kettle boiling?" she might answer, "The heat of the flame is being conducted via the copper bottom of the kettle to the water, increasing the kinetic energy of the water molecules, such that they vibrate so violently that they break the surface tension of the water and are thrown off in the form of steam." Or she might say, "I put it on to make a cup of tea. Would you like some?" The first provides a scientific explanation, the second a personal explanation. Each is a perfectly legitimate form of explanation; indeed, in certain contexts it would be wholly inappropriate to give one rather than the other. Now a first state of the universe *cannot* have a scientific explanation, since there is noth-

122. Or, alternatively, the cause exists changelessly in an undifferentiated time in which temporal intervals cannot be distinguished. On this view God existed literally before creation but there was no moment, say, one hour or one million years before creation. For discussion of this alternative see my *Time and Eternity*, chap. 6.

123. Richard Swinburne, *The Existence of God*, rev. ed. (Oxford: Clarendon, 1991), 32–48.

ing before it, and therefore it cannot be accounted for in terms of laws operating on initial conditions. It can only be accounted for in terms of an agent and his volitions, a personal explanation.

Second, the personhood of the cause of the universe is implied by its timelessness and immateriality. The only entities we know of which can possess such properties are either minds or abstract objects, like numbers. But abstract objects do not stand in causal relations. Indeed, their acausal nature is definitive for abstract objects; that is why we call them abstract.¹²⁴ Numbers, for example, cannot cause anything. Therefore, the transcendent cause of the origin of the universe must be of the order of mind.

Third, this same conclusion is also implied by the fact that we have in this case the origin of a temporal effect from a timeless cause. We've concluded that the beginning of the universe was the effect of a first cause. By the nature of the case, that cause cannot have any beginning of its existence or any prior cause. Nor can there have been any changes in this cause, either in its nature or operations, prior to the beginning of the universe. It just exists changelessly without beginning, and a finite time ago it brought the universe into existence. Now this is exceedingly odd. The cause is in some sense eternal and yet the effect which it produced is not eternal but began to exist a finite time ago. How can this be? If the necessary and sufficient conditions for the production of the effect are eternal, then why isn't the effect eternal? How can all the causal conditions sufficient for the production of the effect be changelessly existent and yet the effect not also be existent along with the cause? How can the cause exist without the effect?

One might say that the cause came to exist or changed in some way just prior to the first event. But then the cause's beginning or changing would be the first event, and we must ask all over again for its cause. And this cannot go on forever, for we know that a beginningless series of events cannot exist. There must be an absolutely first event, before which there was no change, no previous event. We know that this first event must have been caused. The question is: How can a first event come to exist if the cause of that event exists changelessly and eternally? Why isn't the effect co-eternal with its cause?

To illustrate: Let's say the cause of water's freezing is subzero temperatures. If the temperature were eternally below zero degrees Centigrade, then any water around would be eternally frozen. If the cause exists eternally, the effect must also exist eternally. But this seems to imply that if the cause of the universe existed eternally, the universe would also have existed eternally. And this we know to be false.

One way to see the difficulty is by reflecting on the different types of causal relations. In event/event causation, one event causes another. For example, the brick's striking the window pane causes the pane to shatter. This kind of causal relation clearly involves a beginning of the effect in time, since it is a relation between events which

124. See discussion in Paul Copan and William Lane Craig, *Creation out of Nothing: A Biblical, Philosophical, and Scientific Exploration* (Grand Rapids, Mich.: Baker, 2004), 168–70.

occur at specific times. In state/state causation one state of affairs causes another state of affairs to exist. For example, the water's having a certain surface tension is the cause of the wood's floating on the water. In this sort of causal relation, the effect need not have a beginning: the wood could theoretically be floating eternally on the water. If the wood begins to float on the water, then this will be a case of event/event causation: the wood's beginning to float is the result of its being thrown into the water. Now the difficulty that arises in the case of the cause of the beginning of the universe is that we seem to have a peculiar case of state/event causation: the cause is a timeless state but the effect is an event that occurred at a specific moment in the finite past. Such state/event causation doesn't seem to make sense, since a state sufficient for the existence of its effect should have a state as its effect.

There seems to be only one way out of this dilemma, and that is to say that the cause of the universe's beginning is a personal agent who freely chooses to create a universe in time. Philosophers call this type of causation "agent causation," and because the agent is free, he can initiate new effects by freely bringing about conditions which were not previously present. For example, a man sitting changelessly from eternity could freely will to stand up; thus, a temporal effect arises from an eternally existing agent. Similarly, a finite time ago a Creator endowed with free will could have freely brought the world into being at that moment. In this way, the Creator could exist changelessly and eternally but choose to create the world in time. By "choose" one need not mean that the Creator changes his mind about the decision to create, but that he freely and eternally intends to create a world with a beginning. By exercising his causal power, he therefore brings it about that a world with a beginning comes to exist.¹²⁵ So the cause is eternal, but the effect is not. In this way, then, it is possible for the temporal universe to have come to exist from an eternal cause: through the free will of a personal Creator.

On the basis of a conceptual analysis of the conclusion implied by the *kalām* cosmological argument, we may therefore infer that a personal Creator of the universe exists, who is uncaused, beginningless, changeless, immaterial, timeless, spaceless, and unimaginably powerful. This, as Thomas Aquinas was wont to remark, is what everybody means by "God."

Objections

Now certain thinkers have objected to the intelligibility of this conclusion. For example, Adolf Grünbaum, a prominent philosopher of space and time and a vociferous critic of theism, has marshaled a whole troop of objections against inferring God as the Creator of the universe.¹²⁶ As these are very typical, a brief review of his objections should be quite helpful.

125. Such an exercise of causal power plausibly brings God into time, if he was not temporal already. For more on God's relationship to time, see my response to Grünbaum's final objection below.

126. Adolf Grünbaum, "The Pseudo-Problem of Creation in Physical Cosmology," in *Physical Cosmology and Philosophy*, ed. John Leslie, Philosophical Topics (New York: Macmillan, 1990), 92–112.

Grünbaum's objections fall into three groups. Group I seeks to cast doubt upon the concept of "cause" in the argument: (1) When we say that everything has a cause, we use the word "cause" to mean something that transforms previously existing materials from one state to another. But when we infer that the universe has a cause, we must mean by "cause" something that creates its effect out of nothing. Since these two meanings of "cause" are not the same, the argument is guilty of equivocation and is thus invalid. (2) It does not follow from the necessity of there being a cause that the cause of the universe is a conscious agent. (3) It is logically fallacious to infer that there is a *single* conscious agent who created the universe.

But these objections do not seem to present any insuperable difficulties: (1) The univocal concept of "cause" employed throughout the argument is the concept of something which brings about or produces its effects. Whether this production involves transformation of already existing materials or creation out of nothing is an incidental question. Thus, the charge of equivocation is groundless. (2) The personhood of the cause does not follow from the two premises of the cosmological argument proper, but rather from a conceptual analysis of the notion of a first cause of the beginning of the universe, as we have seen. (3) The inference to a single cause of the origin of the universe seems justified in light of the principle, commonly accepted in science, that one should not multiply causes beyond necessity. One is justified in inferring only causes such as are necessary to explain the effect in question; positing any more would be gratuitous. Since the universe is a single effect originating in the Big Bang event, we have no grounds for inferring a plurality of causes.

The objections of Group II relate the notion of causality to the temporal series of events: (1) Causality is logically compatible with an infinite, beginningless series of events. (2) If everything has a cause of its existence, then the cause of the universe must also have a cause of its existence.

Both of these objections, however, seem to be based on misunderstandings. (1) It is not the concept of causality which is incompatible with an infinite series of past events. Rather the incompatibility, as we have seen, is between the notion of an actually infinite number of things and the series of past events. The fact that causality has nothing to do with it may be seen by reflecting on the fact that the philosophical arguments for the beginning of the universe would work even if the events were all spontaneous, causally unconnected events. (2) The argument does not presuppose that everything has a cause. Rather the operative causal principle is that *whatever begins to exist has a cause*. Something that exists eternally and, hence, without a beginning would not need to have a cause. This is not special pleading for God, since the atheist has always maintained the same thing about the universe: it is beginningless and uncaused. The difference between these two hypotheses is that the atheistic view has now been shown to be untenable.

Group III objections are aimed at the alleged claim that creation from nothing surpasses all understanding: (1) If creation out of nothing is incomprehensible,

then it is irrational to believe in such a doctrine. (2) An incomprehensible doctrine cannot explain anything.

But with regard to (1), creation from nothing is not incomprehensible in Grünbaum's sense. By "incomprehensible" Grünbaum appears to mean "unintelligible" or "meaningless." But the statement that a finite time ago a transcendent cause brought the universe into being out of nothing is clearly a meaningful statement, not mere gibberish, as is evident from the very fact that we are debating it. We may not understand *how* the cause brought the universe into being out of nothing; but then it is even more incomprehensible, in this sense, how the universe could have popped into being out of nothing without *any* cause, material or productive. One cannot avert the necessity of a cause by positing an absurdity. (2) The doctrine, being an intelligible statement, obviously does constitute a purported explanation of the origin of the universe. It may be a metaphysical rather than a scientific explanation, but it is no less an explanation for that.

Grünbaum has one final objection against inferring a cause of the origin of the universe: the cause of the Big Bang can be neither *after* the Big Bang (since backward causation is impossible) nor *before* the Big Bang (since time begins at or after the Big Bang). Therefore, the universe's beginning to exist cannot have a cause.¹²⁷ But this argument pretty clearly confronts us with a false dilemma. For why couldn't God's creating the universe be *simultaneous* (or coincident) with the Big Bang? On the view I've defended at length elsewhere, God may be conceived to exist timelessly (or in an undifferentiated time) without the universe and in time from the moment of creation. Perhaps an analogy from physical cosmology will be illuminating. The initial Big Bang singularity is not considered to be part of physical time, but to constitute a boundary to time. Nevertheless, it is causally connected to the universe. In an analogous way, we could say that God's timeless eternity is, as it were, a boundary of time which is causally, but not temporally, prior to the origin of the universe. It seems to me, therefore, that it is not only coherent but also plausible in light of the *kalām* cosmological argument that God, insofar as he exists changelessly alone without creation, is timeless and that he enters time at the moment of creation in virtue of his causal relation to the temporal universe. Given that time began to exist, the most plausible view of God's relationship to time is that he is timeless without creation and temporal subsequent to creation.

None of Grünbaum's objections, therefore, seems to undermine the credibility of the *kalām* cosmological argument for God as the Personal Creator of the universe.

We thus have so far two good arguments for the existence of God: the Leibnizian cosmological argument and the *kalām* cosmological argument. But there's more to come!

127. Adolf Grünbaum, "Pseudo-Creation of the Big Bang," *Nature* 344 (1990): 821–22.